

shindaiwa[®]

OWNER'S AND OPERATOR'S MANUAL

Diesel Engine Generator

DG25MK

Vertical, Water-Cooled 4-Cycle Diesel Engine



CAUTION

Do not operate the Generator, or any other appliance, before you have read and understood the instructions for use and keep near for ready use.

DG25MK-200
X753-008 25 1
X753801-450 1

Introduction

Thank you for purchasing this Shindaiwa soundproof diesel engine generator.

- This manual has been created to ensure safe usage of this generator. Be sure to read this manual before operation. Improper operation/handling of this generator will result in an accident or malfunction.
- Handling/Operation of this generator can only be performed by persons who understand the contents of this manual and can handle/operate the generator in a safe manner. Persons who suffer from an illness, are taking medicine or not feeling way such that safe operation would be negatively affected must not operate this generator.
- Work performed using this generator and handling/operation of this generator must be in accordance with corresponding laws and regulations based on such laws. Consult with the authorized distributor where this generator was purchased if you have any inquiries regarding the corresponding laws.
- Always be sure to include this manual when loaning out this generator and instruct operating personnel to read this manual before operation.
- Store this manual in a specified location where it will be secure and available for consulting at any time. Order another copy from the authorized distributor where this generator was purchased if this manual becomes dusty, grimy or torn.
- Consult with the authorized distributor where this generator was purchased if you have any inquiries regarding any points related to this generator and manual.
When inquiring about this generator, be sure to provide the model name and serial number.
- If disposing of this generator, do so in a manner that is in compliance with laws related to industrial waste. Contact the authorized distributor where the generator was purchased if you have any inquiries regarding proper disposal.

■ Caution notice ranks in this manual are classified as follows.

 **WARNING** : Indicates a potentially hazardous situation which, if not avoided, can result in death or serious injury

 **CAUTION** : Indicates a potentially hazardous situation which, if not avoided, can result in minor or moderate injury and property damage.

< **Note** > : Other types of cautions and indications.

- Note that  **CAUTION** items can also lead to major accidents under some circumstances if not correctly followed.
All caution notices are important. Be sure to follow all of them.

Table of Contents

1. Safety Instructions	2
2. Specifications.....	5
2-1. Specifications	5
2-2. Ambient Conditions	6
3. Applications	6
4. Part Names	6
4-1. External View/Part Names	6
4-2. Operation Panel Part Names	8
4-3. Output Terminal Part Names	9
5. Equipment	10
5-1. Warning Indicators	10
5-2. Meters and Gauges.....	11
5-3. Fuel Piping Switch (3Way Fuel Valve).....	15
6. Transporting/Installing	16
6-1. Transport Procedures.....	16
6-2. Installation Procedures.....	16
7. Load Connections	17
7-1. Load Cable Selection	17
7-2. Connecting Load Cables	18
7-3. Earth Leakage Relay and Grounding	20
8. Pre-Operation Inspection.....	21
8-1. Checking Engine Oil.....	21
8-2. Checking Coolant.....	22
8-3. Checking the Fan Belt.....	23
8-4. Checking the Fuel	24
8-5. Checking for Fuel, Oil and Coolant Leaks	24
8-6. Checking the Battery	25
9. Operating Procedures	25
9-1. Initial Startup/Pre-Check.....	25
9-2. Procedures during Operation	27
9-3. Stopping Operation	27
9-4. Protective Functions.....	28
9-5. Connecting with External Fuel Tank	29
10. Inspection/Maintenance	30
11. Long-Term Storage.....	36
12. Troubleshooting.....	37
13. Generator Circuit Diagram	40
14. Engine Electrical Circuit Diagram	42

1. Safety Instructions



WARNING : SUFFOCATION FROM EXHAUST FUME



- Do not operate the generator in poorly ventilated areas such as indoors or tunnels, as the exhaust gas of the engine contains substances that are harmful to human health.
- Do not direct exhaust fumes at pedestrians or buildings.



WARNING : ELECTRIC SHOCK



- Do not operate the equipment with any doors or covers open.
- Before connecting or disconnecting the load cables to/from the output terminal, always turn the output circuit breakers to the OFF position, stop the engine, and remove the engine key.
- Close the output terminal cover before operating.
- Do not insert a pin, wire or other metal object into the receptacles.
- Do not touch the generator if the Alternator or casing becomes wet during operation.
- Do not touch output terminals or internal electric parts while the generator is operating.
- Ground the every earth grounding terminal to the earth as set out in the manual.
- If even one of all is unconnected by mistake or accident, it will be much more dangerous for human body than the NO-RELAY case, because leaking current inevitably goes through the body.
- Even though all the earth terminals of the loads have been grounded to the earth, the bonnet grounding terminal should be grounded to the earth.
- There is always a danger of being electrocuted by short-circuit. Be sure to test generator's insulation resistance periodically.
- Grounding should be made after the engine is stopped.
- Whenever the Earth leakage relay is activated, you should always repair the leaking place first of all.



WARNING : INJURY



- Close all doors and lock them during operation.
- Close all doors and place locks during operating this equipment, to avoid injuries by unintentionally touching cooling fan and fan belt.
- Before performing any equipment check or maintenance, stop the engine, and remove the engine key. A person performing the maintenance should always keep the key.
- Use the lifting hook to lift the machines, and do not lift up the unit using tie-downs. Use of such could result in the generator falling.
- Do not lift any additional weight such as fuel tanks or trailers.
- No persons should be under a lifted generator.
- Before turning the circuit breaker to ON position, ensure that the breaker or the switch of loads are positioned to OFF.
Operate the circuit breaker, well-communicating with the electrician by the load side.

⚠ CAUTION : EYE/SKIN INJURY



- Wear rubber gloves and other protective wear to protect eyes, skin and clothing from the battery fluid which contains diluted sulfuric acid. If the battery fluid contacts eyes or skin, wash out immediately with a sufficient amount of clean water. Be sure to receive medical treatment, especially if the fluid contacts the eyes.

⚠ CAUTION : EXPLOSION



- Never use or recharge the battery if the fluid level is below the minimum level.
- Do not create sparks or bring flame near the battery as it generates flammable gas.

⚠ CAUTION : FIRE



- Do not bring flammable items (such as fuel, gas and paint) or items that are highly combustible near the generator as the muffler, exhaust gas and other parts become extremely hot.
- Keep this generator 1m or more from walls or other hindrances, and on a level surface.
- Do not connect the generator output to indoor wiring.
- This generator uses diesel fuel. Always be sure to stop the engine and not bring flames close when inspecting fuel or refueling. Wait until the engine has cooled before performing such procedures.
- Do not use this equipment when leak is found, and repair the leaking location before operating.
- Always be sure to wipe up any spilled fuel or oil.
- Allow the generator to cool before covering with the protective cover.
- Never allow flame to come close to the generator.

⚠ CAUTION : BURNS



- Do not touch the engine and surrounding components immediately after stopping the equipment, while temperature can reach extremely high.
- Do not open the radiator cap immediately after stopping the engine, to avoid sustaining burns from hot vapor.
- Hot steam gushes out from the coolant sub-tank if the generator overheats. Do not touch the coolant sub-tank.
- Always be sure to stop the engine and allow the engine to cool when performing inspection or maintenance of engine oil. Opening the oil level indicator or oil filler cap during operation will result in hot oil cause personal injury.

⚠ CAUTION : INJURY

- Always be sure to use lifting hooks when moving the generator, and lift it slowly at a completely vertical angle.
- Personnel performing lifting work must wear protective gear such as helmets, safety shoes and gloves.
- Remove the wood ties if using anchors to secure the generator.
- Position the generator on a level stable surface so that it cannot slide or move in any manner.
- Before starting operation, always be sure to turn off all switches of equipment using the generator and all breakers to OFF.
- Do not move the generator during operation.
- Do not operate the generator if it has been modified or any parts have been removed.

⚠ CAUTION : PROPERTY DAMAGE

- If using this generator for medical equipment, check before use with the medical equipment manufacturer, doctor, hospital or similar entity.
- Check that the generator output setting, output terminal connection and load power source are consistent.
- Cable burnout can occur due to generated heat if the load current exceeds the allowable current of the cable.
- The voltage drop between cables is large if the cable is excessively long or thin, resulting in decreased input voltage to equipment using the generator, thereby causing decreased performance, faulty operation and malfunction.

■ Warning/Caution Label Locations

If warning or caution labels become damaged and difficult to read, replace with new labels in the indicated locations. Order labels using part number indicated in the parenthesis.

- | | |
|------------------------|--------------------------|
| ① Injury | (Part no. : X505-007550) |
| ② Electric shock | (Part no. : X505-007560) |
| ③ Caution: gm spec LLC | (Part no. : X505-007840) |
| ④ Caution: fire | (Part no. : X505-007650) |
| ⑤ Caution | (Part no. : X505-008690) |
| ⑥ Injury | (Part no. : X505-010350) |
| ⑦ Burn | (Part no. : X505-007830) |

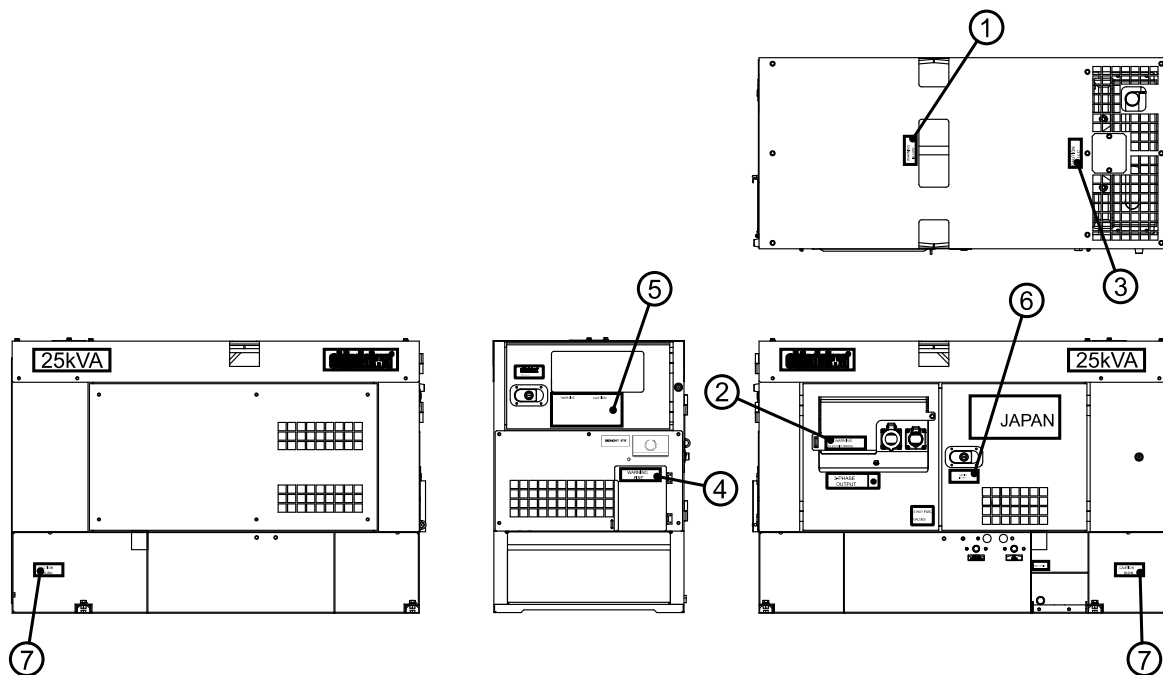

2. Specifications

2-1. Specifications

Model		Unit	DG25MK-200	
Alternator	Generating Type	-	Rotating Filed, Brushless 3-Phase Synchronous Alternator	
	Rated Frequency	Hz	50	60
	Rated Output	kVA	20	25
		kW	16	20
	Rated Voltage	V	200 [400] *1	220 [440] *1
	Rated Current	A	57.7 [28.9] *1	65.6 [32.8] *1
	Winding	-	3-phase, 4-wire	
	Power factor	%	80	
	Insulation class	-	F	
	Excitation	-	Self-Excitation(Brushless)	
No. of poles	-	4		
Engine	Types	-	Vertical Water-cooled 4-cycle Diesel Engine	
	Model (Manufacturer)	-	V2403 (KUBOTA)	
	No. of Cylinders (bore x stroke)	mm	4 (87 X 102.4)	
	Continuous rated output	kW	19.1	23.7
		PS	26.0	32.2
	Rated speed	min ⁻¹	1500	1800
	Displacement	L	2.434	
	Combustion system	-	Direct Fuel Injection	
	Cooling method	-	Radiator	
	Lubricating method	-	Forced lubrication	
	Starting method	-	Electric start	
	Fuel	-	Diesel Fuel (ASTM No. 2-D)	
	Lubricant oil	-	CF class	
	Fuel tank capacity	L	65	
	Lubricant volume (Full)	L	9.7	
	Cooling water volume	L	9.7	
	Starting motor capacity	V-kW	12 - 1.4	
Charging dynamo capacity	V-A	12 - 30		
Battery	-	80D26R		
Unit	Length	mm	1500	
	Width	mm	700	
	Height	mm	1000	
	Dry Weight	kg	625	
	Installed Weight	kg	705	

*1: The values in brackets are optional data, when modified to 400/440V by the dealers only.

As default 3-phase output is set at 200/220V, contact your authorized distributor to adjust the terminal lug setting and replace the receptacles if necessary to obtain 400/440V for 3-phase output.

2-2. Ambient Conditions

Use this generator in ambient conditions as described below. Failure to provide these conditions can result in problems such as malfunction, insufficient output and reduced durability.

- Ambient temperature: -15 to 40 degree Celsius
- Relative humidity: 85% or less
- Elevation: 300 m or less

3. Applications

- Power source for submerged pumps and similar civil engineering equipment
- Power source for lighting and similar equipment
- Power source for electrical tools and household appliances

⚠ CAUTION : PROPERTY/SECONDARY DAMAGE

- Do not use for any application other than those listed above.
- If using this generator for medical equipment, check before use with the medical equipment manufacturer, doctor, hospital or similar entity.

4. Part Names

4-1. External View/Part Names

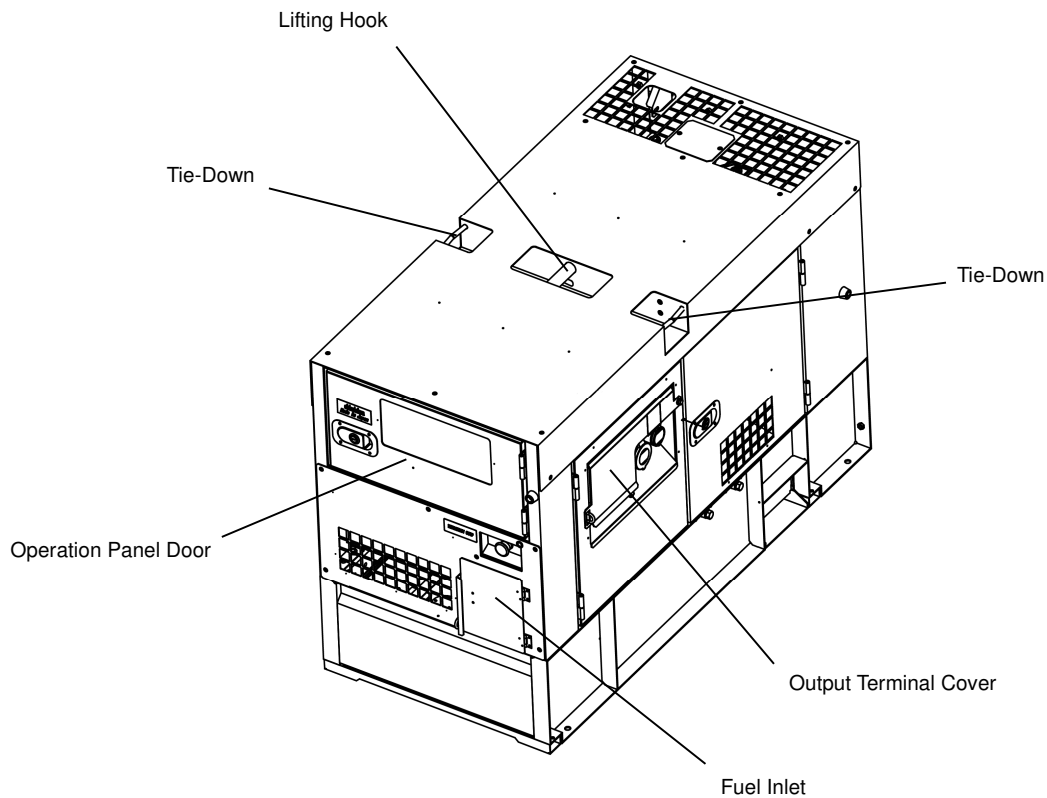

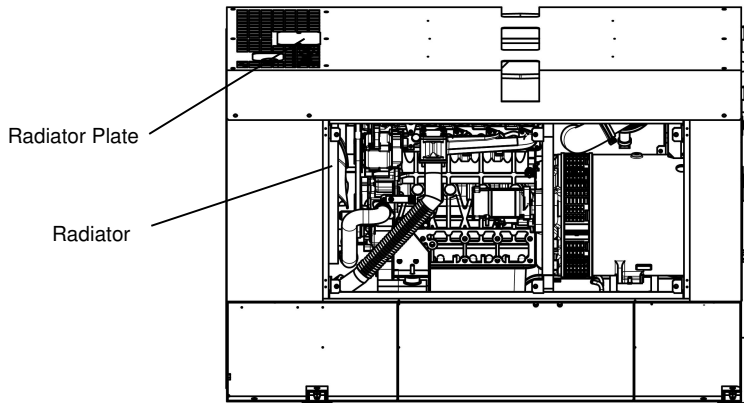

* Shown with side-plate removed.

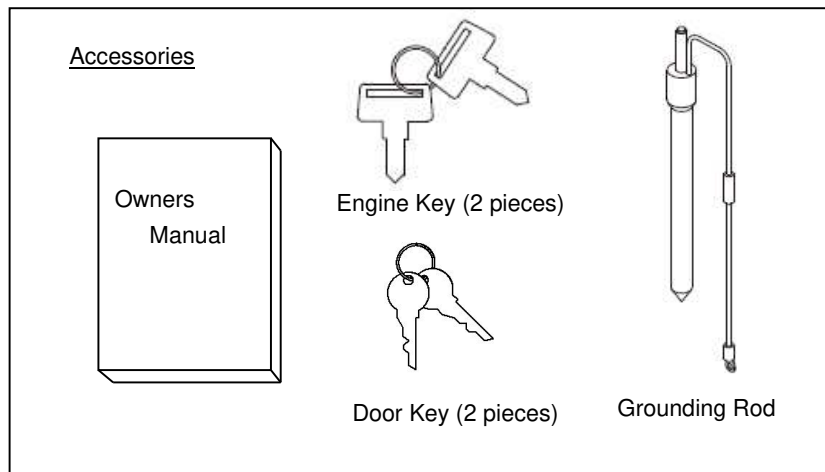
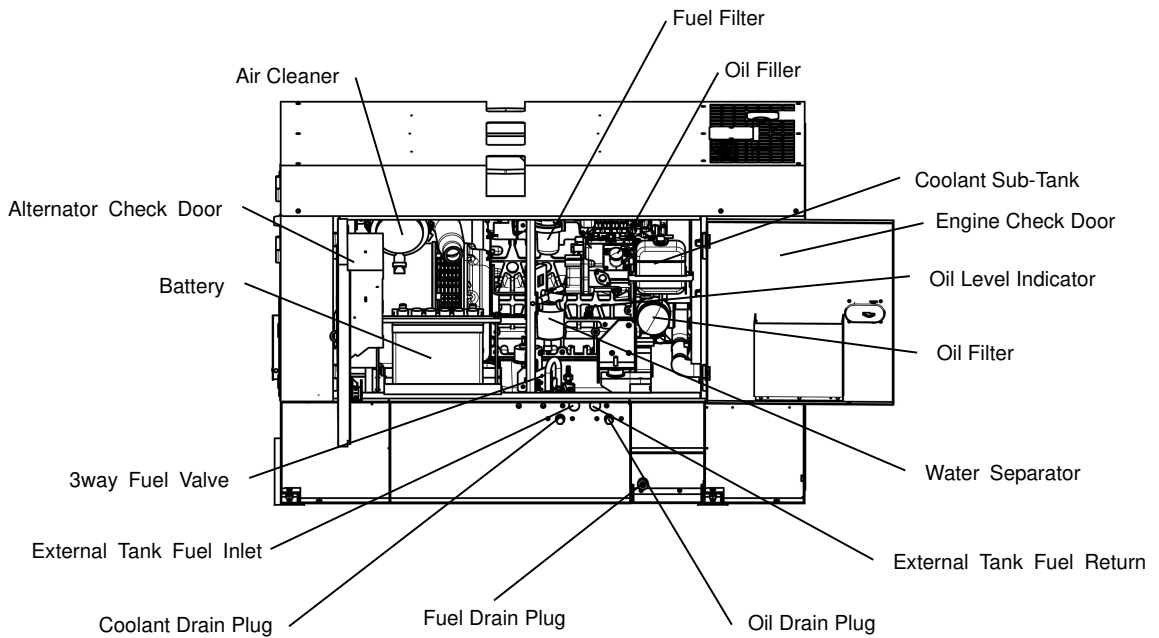

4-2. Operation Panel Part Names

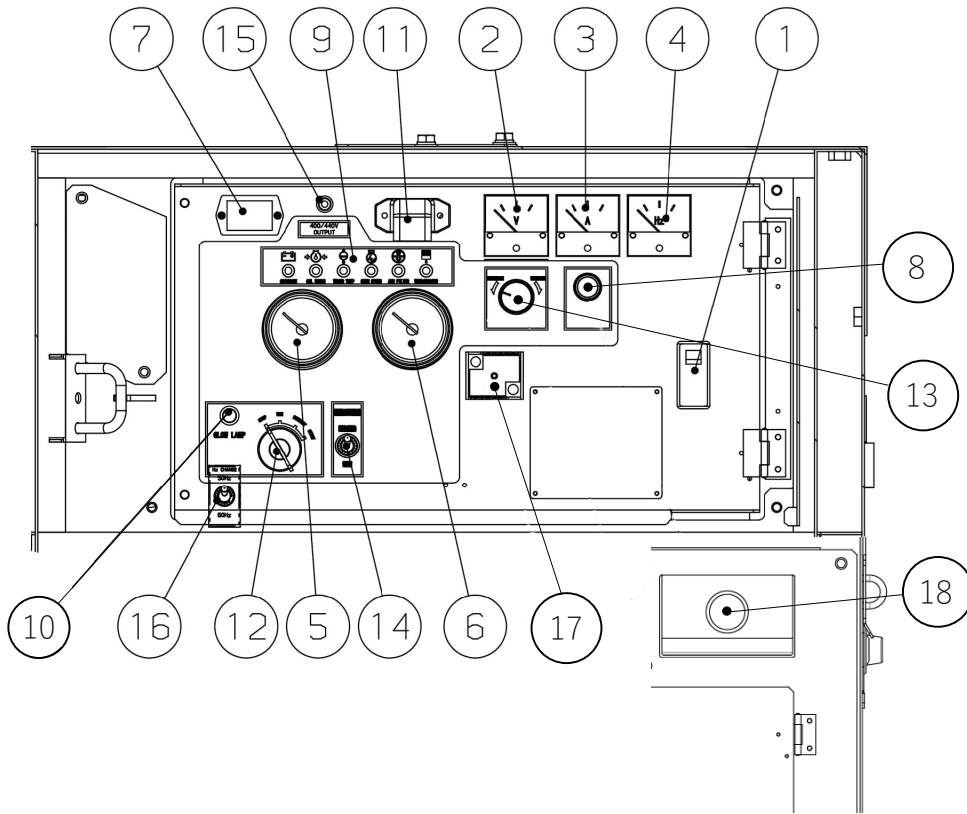

①	Circuit Breaker	⑪	Pilot Lamp
②	Voltmeter	⑫	Starter Switch
③	Ammeter	⑬	Voltage Regulator
④	Frequency Meter	⑭	Throttle Switch
⑤	Water Temperature Gauge	⑮	400/440V Output Lamp
⑥	Fuel Gauge	⑯	Frequency Selector Switch (inside)
⑦	Hour Meter	⑰	Earth Leakage Relay
⑧	Over Load Pre-caution Lamp	⑱	Emergency Stop Button
⑨	Warning Indicators		
⑩	Preheat Lamp		

4-3. Output Terminal Part Names

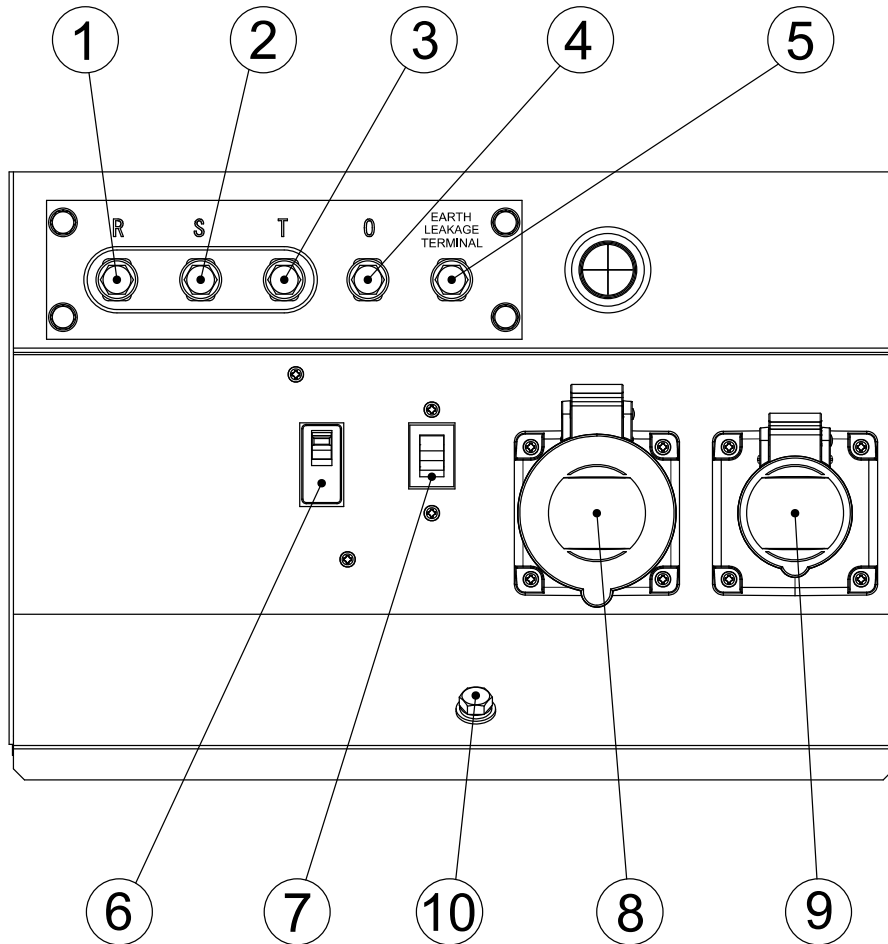

①	3-Phase Output Terminal "R"	⑥	3-Phase Circuit Breaker (32A)
②	3-Phase Output Terminal "S"	⑦	1-Phase Circuit Breaker (15A)
③	3-Phase Output Terminal "T"	⑧	3-Phase Receptacle
④	3-Phase Output Terminal "O"	⑨	1-Phase Receptacle
⑤	Earth Leakage Terminal	⑩	Bonnet Grounding Terminal

5. Equipment

5-1. Warning Indicators

⚠ WARNING : INJURY

- Close all doors and place locks during operation, to avoid injuries by unintentionally contact with moving parts such as the cooling fan and fan belt.
- Before performing any equipment check or maintenance, stop the engine, and remove the engine key. A person performing the maintenance should always keep the key.

⚠ CAUTION : BURNS

- Do not touch the engine and surrounding components immediately after stopping the equipment, while temperature can reach extremely high.

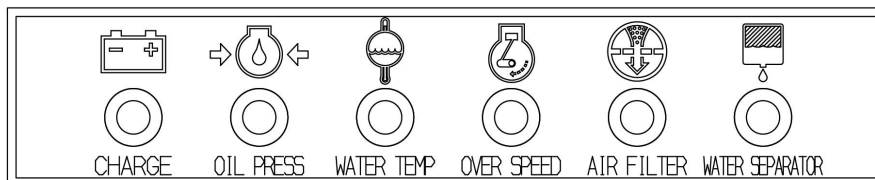

This generator is equipped with the following warning indicators: CHARGE (battery charge), OIL PRESS (engine oil pressure), WATER TEMP (coolant temperature), OVER SPEED (engine overspeed), AIR FILTER (air cleaner clogging), and WATER SEPARATOR (water separator amount). An indicator lights up if a malfunction/fault occurs during operation and the engine automatically stops depending on the fault type. If the equipment is normal, the CHARGE and OIL PERSS warning indicators light up when the starter switch is switched from STOP to RUN, and all warning indicators turn off when the engine is started.

(1)WATER TEMP (Coolant Temperature) Warning Indicator (High Water Temp.)

⚠ CAUTION: BURNS

- Do not open the radiator cap immediately after stopping the engine. Do so will result in hot steam gushing out.
- Hot steam gushes out from the coolant sub-tank if the generator overheats. Do not touch the coolant sub-tank.

If the coolant temperature rises above 115 °C during operation, the WATER TEMP and ENGINE warning indicators light up, and the engine automatically stops. If this occurs, hot steam will gush out of the coolant sub-tank. Check the coolant sub-tank coolant level after the generator cools and add coolant to the coolant sub-tank if it is insufficient. (Refer to section "8-2. Checking Coolant".) If the coolant is at the specified amount, it is probable that the fan belt is loose or there is a coolant leak. Wait for the engine to cool and inspect for these problems.

< Note >

- The coolant temperature cannot be detected if the coolant level is excessively low. Always be sure to check the coolant level in the radiator coolant sub-tank before starting work.

(2) OIL PRESS (engine oil pressure) Warning Indicator (Low Oil Press.)

CAUTION: BURNS

- Always be sure to stop the engine and allow the engine to cool when performing inspection or maintenance of engine oil. Opening the oil gauge or oil filler cap during operation will result in hot oil gushing out.

If the engine oil pressure drops below 0.49 x 100 kPa during operation, the OIL PRESS and ENGINE warning indicators light up, and the engine automatically stops. If this occurs, check the engine oil level and add engine oil until it reaches the maximum level.

< Note >

- This oil pressure warning indicator cannot detect oil deterioration. Change the engine oil periodically. (Refer to section “8-1. Checking Engine Oil”.)

(3) OVER SPEED (Engine Overspeed) Warning Indicator

This generator is equipped with a function such that the engine is automatically stopped if an engine fault occurs causing the engine speed to increase excessively. If the engine speed rises above 2070 min⁻¹ during operation, the OVER SPEED and ENGINE warning indicators light up, and the engine automatically stops. If this occurs, it is probable that some malfunction has occurred in the engine. Contact the authorized distributor where the generator was purchased.

(4) CHARGE (Battery Charge) Warning Indicator (Low Battery Voltage)

The BATTERY warning indicator lights up when charging is not possible during operation. If charging is not possible and the battery voltage drops below 8 V, the ENGINE warning indicator also lights up and the engine automatically stops. If this occurs, contact the authorized distributor where the generator was purchased.

< Note >

- This battery charging warning indicator cannot detect battery deterioration or insufficient battery fluid. (Refer to section “8-6. Checking the Battery”.)

(5) AIR FILTER (Air Cleaner Clogging) Warning Indicator

The AIR FILTER warning indicator lights up if the air cleaner element becomes clogged during operation. If it lights up, immediately stop the engine and clean or replace the air cleaner element. (Refer to section “10. Inspection/Maintenance (3) Air Filter Element Cleaning/Replacement”.)

(6) WATER SEPARATOR (Water Separator Amount) Warning Indicator

The WATER SEPARATOR warning indicator lights up if the liquid stored in the water separator exceeds approximately 110 ml during operation. If it lights up, immediately stop the engine and drain the liquid stored in the water separator.

(Refer to section “10. Inspection/Maintenance (4) Draining Liquid in Water Separator”.)

5-2. Meters and Gauges

Engine Meters and Gauges

(1) Hour Meter

Displays the operating time. Use this to schedule periodic inspection. Be careful as the hour meter operates when the starter switch is at RUN regardless of whether the engine is running or stopped.

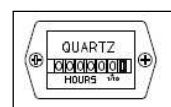

(2) Water Temperature Gauge

Water Temperature Gauge displays the temperature of engine coolant. Normal temperature may vary depending on the environment, but it should be between 75 to 90 °C.

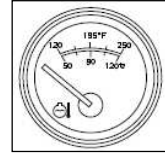

< Note >

- If the temperature exceeds normal value, disconnect the load, idle the engine at 1000min⁻¹, and wait until the reading falls to the normal temperature range.

(3) Fuel Gauge

It shows the volume in the fuel tank. When filled up, it shows 『F』. When the hand is approaching to 『E』, the volume is coming to empty. Replenish fuel enough promptly.

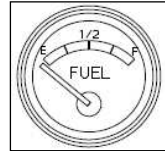

Generator Meters and Gauges

(1) Voltmeter

The voltmeter displays the 3-phase output voltage (voltage between R-T) from the generator.

Check that 200V is displayed at 50Hz and 220V at 60Hz during operation.

*Check that 400V is displayed at 50Hz and 440V at 60Hz during operation if using at the 3-phase 400V setting.

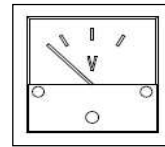

(2) Ammeter

Ammeter displays the output current (Phase) from the generator.

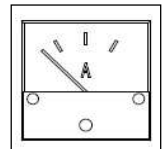

(3) Frequency Meter

Frequency Meter will display the frequency of the generator.

Please check it showing 50Hz or 60Hz during operation.

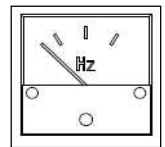

Lamps

(1) Preheat Lamp

When the starter switch is turned to <Preheat> position, the preheat lamp will be turned ON. The preheat lamp will be turned OFF after preheating completes showing the engine start possible.

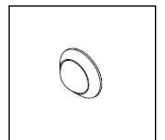

< Note >

- Preheating time varies to coolant temperature, usually about 3-10 seconds.

(2) Pilot Lamp

This lights up when the engine is operating to indicate that power is being generated.

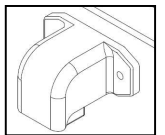

(3) Over Load Pre-caution Lamp , and Output Terminal for Lighting of Additional Lamp (Aux Lamp Terminal)

This lamp starts to flash if the output current exceeds around 80% of the rated current. Use this generator in a range that does not exceed the rated current while the lamp is flashing. The lamp turns off when the output current drops below 80% of the rated current.

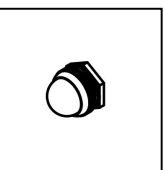

This generator is equipped with an Aux Lamp Terminal. DC 12 V is output to the Aux Lamp Terminal at the same time as when the Over Load Pre-caution Lamp is flashing.

Refer to the circuit drawing below if using the Aux Lamp Terminal for a lamp or similar device with a different setting.

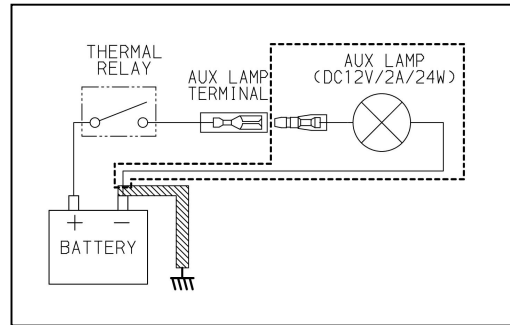
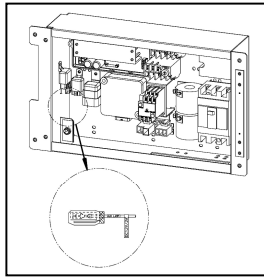

< Note >

- Connect a lamp that is DC12V/2A/24W or less to the Aux Lamp Terminal.
- Pre-caution lamp flushing may take time, as thermal relay detects overload by bimetallic strip systems.

(4) 400/440V output Lamp

This lamp lights up if 400/440V are output from the output terminal and turns off if 200/220V are output. Check the rated voltage of the device being used.

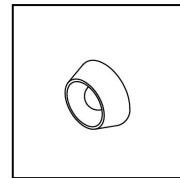

< Note >

- Check that the voltages of the generator output setting, output terminal connection and load power source are consistent.

Switches

(1) Starter Switch

1. Stop
When the switch is set to this position, all power will be off.
The switch must be set to this position to remove the key.
2. Run
The switch must be set to this position during operation.

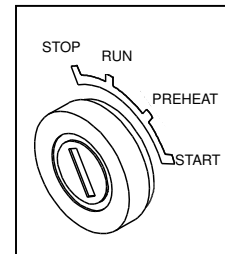

< Note >

- Do not leave the switch to this position, while the engine is stopped. Otherwise the battery is discharged.
3. Preheat
This position is used during cold season, to preheat Glow Plug.
 4. Start
This position is to start the engine. When the key is released, the setting will automatically return to <Run> position.

(2) Emergency Stop Button

This button is used to stop the engine in emergency. By inserting the button, the engine stops. Be sure to restore the Starter Switch to STOP and re-set the button, turning clockwise after using the emergency stop button.

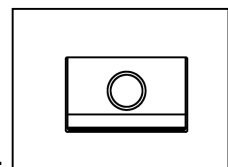

(3) Circuit Breaker

By turning this circuit breaker on the control panel to ON, Power will be transferred to the load side. The breaker trips to OFF, either overload or short-circuit.

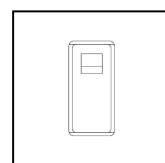

(4) 3-Phase Earth Leakage Relay

When current leak occurs, it trips to stop power transmission to load.

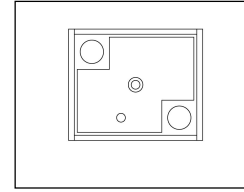

< Note >

- Do not use this relay as the ON/OFF switch to the load.

Voltage Regulator and Throttle Lever

(1) Voltage Regulator

The dial adjusts generator output voltage.

By turning the dial clockwise, an operator can increase the voltage.

By turning the dial counter-clockwise, an operator can decrease the voltage.

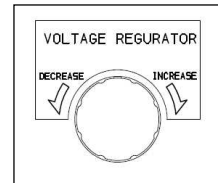

(2) Throttle Switch

The switch is to change engine speed (revolution). Turn the switch to [IDLING] when engine start, warm-up or cool-down, and turn to [RUN] when using the equipment at the rated speed.

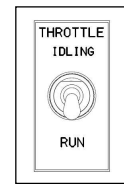

(3) Frequency Selector Switch

This switch changes the frequency between 50Hz and 60Hz, and is located inside the operation panel. Loosen the two screws to open the operation panel and check that the internal frequency switch is properly set to the frequency being used.

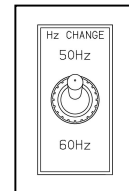

< Note >

- Check that no loads are connected before using the frequency switch.
- This switch is set to 60Hz when shipped from the factory. Set to 50Hz in 50Hz regions.

Over-Current Protectors

(1) Thermal Relay (Over Load)

This relay sends a trip signal to the circuit breaker when an over-current flows in the circuit. When the breaker is tripped, it is set at the middle between ON and OFF. If this occurs, reset the breaker according to the following procedure.

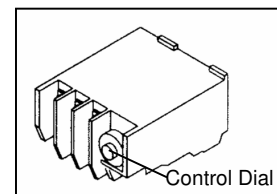

- 1 Stop the engine.
- 2 Wait approximately 1 minute before attempting to reset the main breaker to allow the thermal relay to automatically reset.
- 3 Turn the main breaker to the "OFF" position.
- 4 Turn the breaker to the "ON" position.

If changing the frequency or voltage, change the Thermal Relay (Over Load) adjustment dial according to the following table.

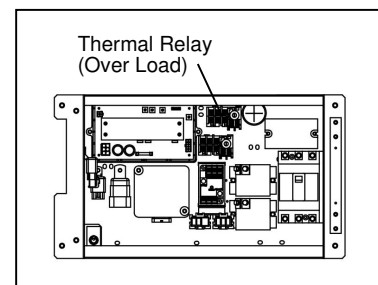

	FREQUENCY			
	50Hz		60Hz	
Output Volt	200V	208V	200V	220V
Adjustment Dial Value	2.9	2.8	3.6	3.3

(2) Thermal Relay (Over Load Pre-caution Lamp)

If changing the frequency or voltage, change the Thermal Relay (Over Load Pre-caution Lamp) adjustment dial according to the following table.

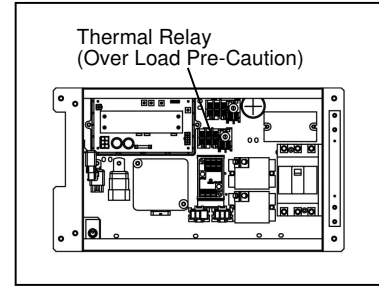

	FREQUENCY			
	50Hz		60Hz	
Output Volt	200V	208V	200V	220V
Adjustment Dial Value	2.2	2.1	2.7	2.5

5-3. Fuel Piping Switch (3Way Fuel Valve)

⚠ CAUTION : FIRE

- Always make sure that the engine is stopped when working on piping.
- Always be sure to wipe up any spilled fuel.
- After working on the piping, check that there is no fuel leakage.

Change the 3-way fuel valve to switch to supply fuel from the external tank. In that case, the internal fuel tank is not used.

(1) If using the internal fuel tank

The 3-way fuel valve is turned to the "A" side when the generator is shipped from the factory.

< Note >

- When disconnecting piping from the external tank, turn the lever to the "A" side, and attach the connecting hose to the external tank fuel inlet/return.

(2) If using an external fuel tank

Connect hoses from the external fuel tank to the external fuel inlet and the external fuel return. Change the lever of the 3way fuel valve to the "B" side to supply fuel from the external tank.

(Refer to "9-5. Connecting an External Fuel Tank" for corresponding procedures.)

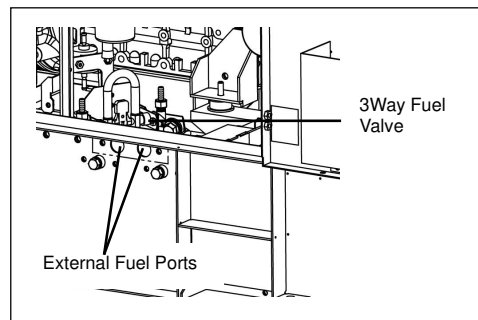
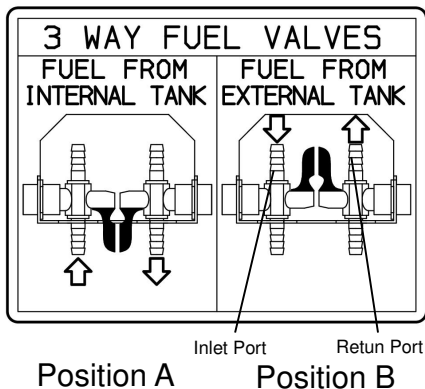

6. Transporting/Installing

6-1. Transport Procedures

⚠ WARNING : INJURY

- Do not lift up the unit using tie down. Use of such could result in the generator falling.
- No persons should be under a lifted generator.

⚠ CAUTION : INJURY

- Always be sure to use lifting hooks when lifting up the generator, and raise it slowly at a completely vertical angle.
- Personnel performing lifting work must wear protective gear such as helmets, safety shoes and gloves.
- Do not move the generator during operation.

(1) Lifting Procedures

Always be sure to use lifting hooks when lifting up the generator, and raise it slowly at a completely vertical angle.

(2) Transport

When transporting this generator, tie rope to the left and right tie downs, and securely fix the generator.

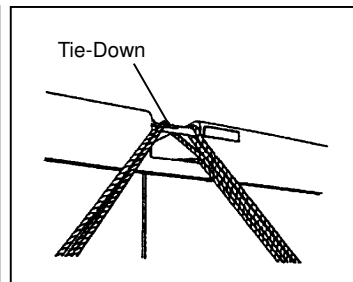
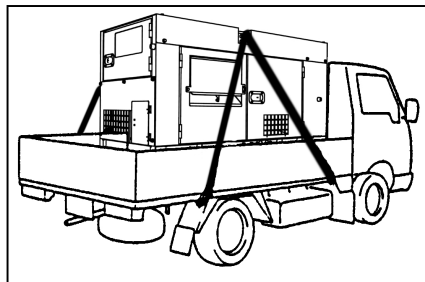
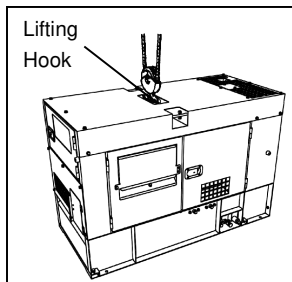

< Note >

- Handle this generator with great care when raising, lowering and transporting. Rough handling of generator can result in damage or malfunction.

6-2. Installation Procedures

⚠ WARNING : SUFFOCATION FROM EXHAUST FUME

- Do not operate the generator in poorly ventilated areas such as indoors or tunnels, as the exhaust gas of the engine contains substances that are harmful to human health.
- Do not direct exhaust fumes at pedestrians or buildings.

⚠ CAUTION : FIRE

- Do not bring flammable items (such as fuel, gas and paint) or items that are highly combustible near the generator as the muffler, exhaust gas and other parts become extremely hot.
- Keep this generator 1m or more from walls or other hindrances, and on a level surface.
- Remove the wood ties if using anchors to secure the generator
- Do not connect the generator output to indoor wiring.

- If installing this generator, set up barriers or fencing completely around the boundary line of the construction area and take measures to prevent persons not involved in the construction from entering the area.
- Always set the generator on a hard, flat and leveled surface that serves as the foundation.
- Keep the generator 1 m or more from walls or other hindrances so that the operation panel door and left/right check doors are accessible for internal inspection/maintenance.

< Note >

- This equipment must be operated on hard and flat surface. Operating under any other conditions may result in malfunctions.
- Do not block the airflow from radiator vent or muffler exhaust. It may result in reduced engine performance, overheating, or damage to the electrical parts.
- Operating in dusty area or salty air (by the ocean), or any other particulate environment may result in clogged radiator, which may cause overheating, other malfunctions and insulation deterioration. Use extreme care, frequent checks and maintenance.

7. Load Connections

7-1. Load Cable Selection



CAUTION : PROPERTY DAMAGE

- Cable burnout can occur due to generated heat if the load current exceeds the allowable current of the cable.
- The voltage drop between cables is large if the cable is excessively long or thin, resulting in decreased input voltage to equipment using the generator, thereby causing decreased performance, faulty operation and malfunction.

Select cable for use that has sufficient thickness and an allowable current possible for use, giving consideration to the distance from the generator to the equipment using the generator.

< Note >

- Select cable with a thickness that ensures that the voltage drop across the cable will be within 5% of the rated voltage.

■ Load Cable Selection Tables

(Ex.) If used voltage is 220V and voltage drops by 11 V.

3-phase: Cabtyre cables

(Unit: AWG)

Length Current	100 ft (30 m) or less	200 ft (61 m)	300 ft (91 m)	400 ft (122 m)	500 ft (152 m)	600 ft (183 m)
20 A	12	10	8	8	6	6
40 A	8	6	6	6	4	4
60 A	6	6	4	4	2	2
80 A	6	4	4	2	2	1/0

(Unit: mm²)

Length Current	50 m or less	75 m	100 m	125 m	150 m	200 m
20 A	3.5	5.5	8	8	14	14
40 A	8	14	14	14	22	22
60 A	14	14	22	22	30	38
80 A	14	22	22	30	38	50

(Ex.) If used voltage is 100V and voltage drops by 5V.

1-phase: Cabtyre cables

(Unit: AWG)

Length Current	100 ft (30 m) or less	200 ft (61 m)	300 ft (91 m)
10A	10	10	8
20A	8	6	4
30A	6	4	4
40A	4	2	2

(Unit: mm²)

Length Current	50 m or less	75 m	100 m
10A	5.5	5.5	8
20A	8	14	22
30A	14	22	22
40A	22	30	30

7-2. Connecting Load Cables

WARNING : ELECTRIC SHOCK

- Before connecting or disconnecting the load cables to/from the output terminal, always turn the output circuit breakers to the OFF position, stop the engine, and remove the engine key.
The person performing the maintenance should always keep the key.
- Close the output terminal cover before operating.
- Do not insert a pin, wire or other metal object into the receptacles.
- Do not touch the generator if the Alternator or casing becomes wet during operation.

CAUTION : FIRE

- Do not connect the generator output to indoor wiring.

< Note >

- When connecting a load, check that the generator output setting, output terminal connection position, and load power source are all matching.
- If using the O terminal, be careful that the currents of each phase are uniform.
- Use proper tools when connecting a load to sufficiently tighten the connection. Failure to sufficiently tighten the connection will result in cable burnout.

(1) 3-Phase Output Terminal

■ For 3-phase load:

- Terminal voltage is 200/220 V [400/440] (50/60Hz).
- * The values in brackets are for when set to 400/440V.

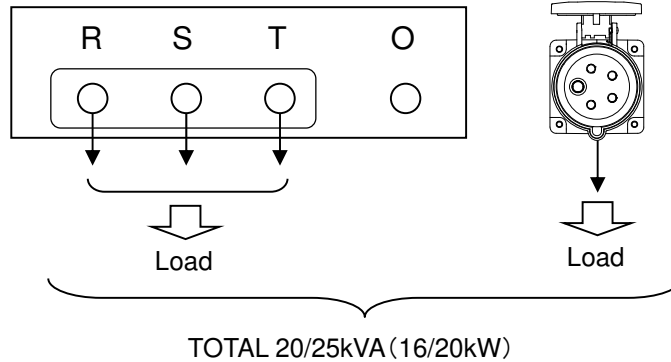

■ For 1-phase load:

- Terminal voltage is 115/127 V [230/254 V] (50/60Hz).
- * The values in brackets are for when set to 400/440V.

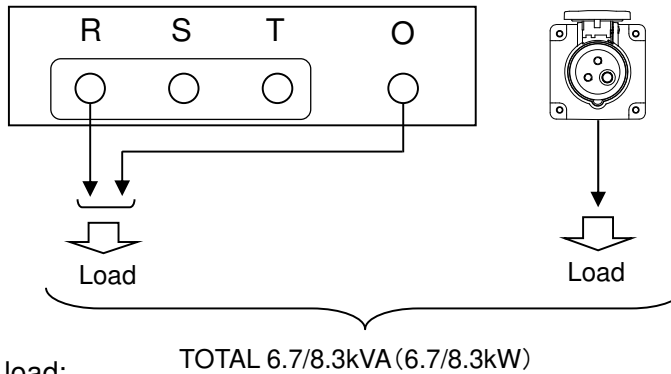

■ For 1-phase load:

- Terminal voltage is 200/220 V [400/440 V] (50/60Hz).
- * The values in brackets are for when set to 400/440V.

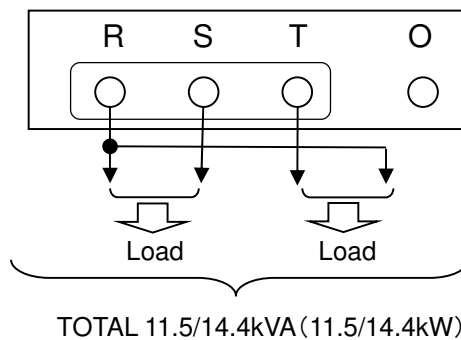

Total output capacity

Unit	3-phase load	1-phase load		Total
	R-S-T	R-O	R-S , R-T	
kVA	20/25	6.7/8.3	11.5/14.4	20/25
kW	16/20	6.7/8.3	11.5/14.4	16/20

7-3. Earth Leakage Relay and Grounding

⚠ WARNING : ELECTRIC SHOCK 

- Ground the every grounding terminal to the earth as set in the manual.
- If even one of all is unconnected by mistake or accident, it will be much more dangerous for human than the NO-RELAY case, because leaking current inevitably goes through the body.
- Even though all the bonnets of the loads have been grounded to the earth, the bonnet grounding terminal should be grounded to the earth.
- Grounding should be made after the engine is stopped.
- Whenever the Earth leakage relay is activated, you should always repair the leaking place first of all.

The generator is provided with the earth leakage breaker relay to detect any leakage produced due to such the trouble as insulation failure of the load while the generator is running and to cut off the circuit for protection against any accident such as electrical shock resulting from the trouble. The specification of the earth leakage relay ;

- Rated Sensitive Current: 30mA (or below) (Grounding resistance: 500Ω or below)
- Sensitive time: Within 0.1 second.

(1) Grounding Work

The qualified electrician should perform the grounding of the following 3 points(500 Ω or below).

- The Bonnet grounding terminal of the generator.
- The Earth leakage terminal of the generator.
- The Bonnet of the load.

< Note >

- In the event you cannot ground the generator to the earth, consult with the authorized distributor or our engineering section.

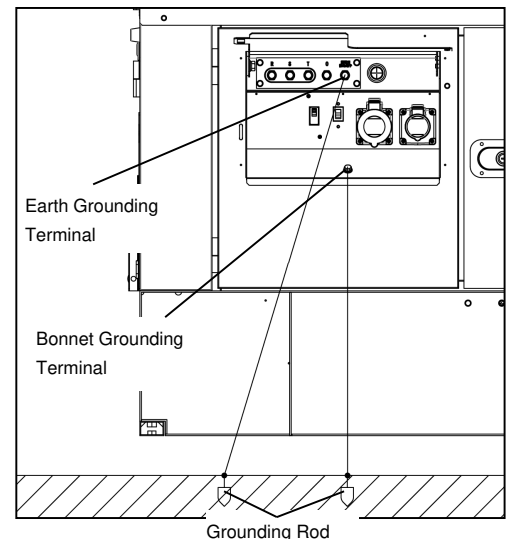

(2) Operation Check

⚠ WARNING : ELECTRIC SHOCK 

- Before turning the circuit breaker to ON position, ensure that the breaker or the switch of loads are positioned to OFF. Operate the circuit breaker, well-communicating with the electrician by the load side.

Before operating the generator, check always if the device can work.

● Actuation test of the Earth Leakage Relay and Breaker

1. Ensure that the breaker and the switches of loads are positioned to OFF.
2. Ensure that the circuit breaker positioned to OFF. (Refer to "4-2.Operation Panel")
3. Following the procedure in 9-1, **Initial Startup / Pre-Check**, start an engine.

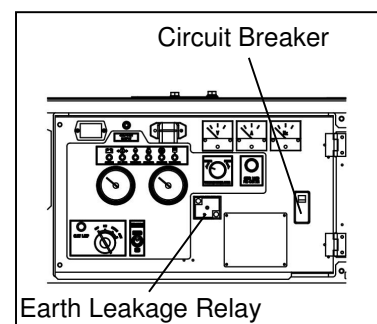

- 4 Turn breaker to ON .
- 5 Push the TEST button on Earth Leakage Relay.
When the button is pushed, the earth leakage indicator turns ON and circuit breakers are positioned in the middle between ON and OFF positions simultaneously, the device works normally.
- 6 Push the reset button. The earth leakage indicator turns OFF subsequently.
- 7 Turn (Push-down) the circuit breaker (lever) to OFF position.

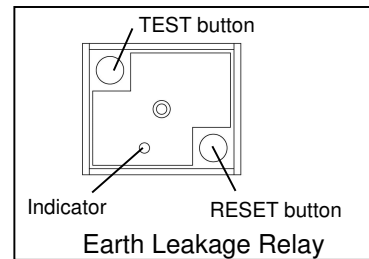

In the event you cannot complete every step of the above procedure to the end, the device is out of order. Consult with our authorized distributor or our engineering section and ask to repair.

(3) Earth leakage Relay has activated

If the earth leakage breaker relay has been activated, the earth leakage indicator turns ON, and the breaker (lever) is tripped and positioned in the middle between ON and OFF. When this occurs, stop the engine and repair the location of earth leakage before restarting operation. (In the case the earth leakage indicating lamp does not turn to ON simultaneously, the cause is Over-Loaded.)

8. Pre-Operation Inspection

! WARNING : ELECTRIC SHOCK/INJURY

- Before performing any equipment check or maintenance, stop the engine, and remove the engine key. A person performing the maintenance should always keep the key.
- Close all doors and place locks during operating this equipment, to avoid injuries by unintentionally touching cooling fan and fan belt.

! CAUTION : BURNS

- Do not touch the engine and surrounding components immediately after stopping the equipment, while temperature can reach extremely high.

! CAUTION : FIRE

- Always be sure to wipe up any spilled fuel or oil.

8-1. Checking Engine Oil

To check the engine oil, keep the equipment in leveled position, remove the oil level indicator and wipe so that no oil remains, and then re-insert the dipstick fully. Prior to starting the engine, make sure to fill the engine oil through the oil filler until it reaches the MAX line.

< Note >

- Wait approximately five minutes or more after stopping the engine or adding oil before checking the oil level again.
- An accurate oil level reading cannot be obtained if the generator is not placed in leveled position.

- Do not overfill with oil to avoid engine damage.

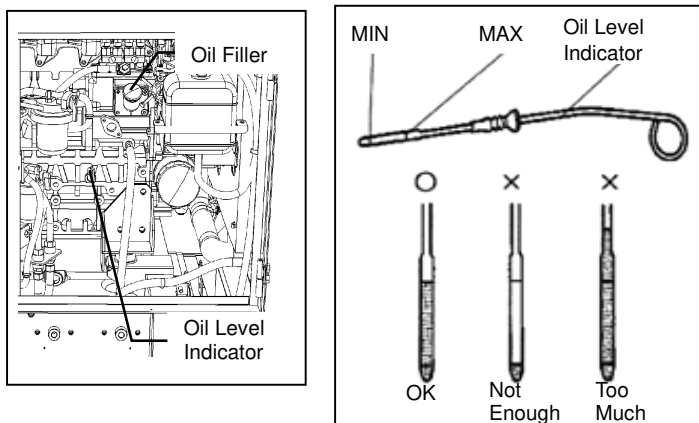

(1) Types of Engine Oil

Use only API service-type CF class.

(2) Engine Oil Viscosity

Use a diesel engine oil with an appropriate viscosity corresponding to the ambient temperature (refer to the table).

- Relation of Viscosity/Temperature

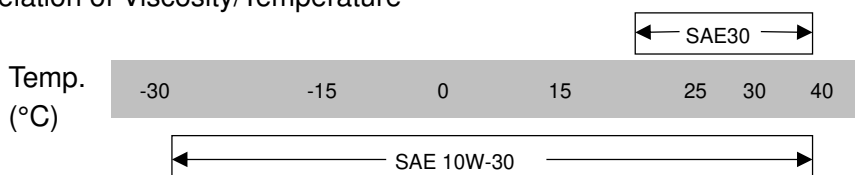

(3) Engine Oil Replacement Amount

(Unit: L)

Total Lubrication Oil Amount
9.7 (0.3)

Value in parenthesis is the filter capacity.

8-2. Checking Coolant

⚠ CAUTION : BURNS 

- Do not open the radiator cap immediately after stopping the engine. Do so will result in steam gushing out.
- Hot steam gushes out from the coolant sub-tank if the generator overheats. Do not touch the coolant subtank.

Check that the subtank coolant level is in between FULL and LOW. If the subtank coolant is lower than the LOW level, add coolant to the subtank and radiator.

(1) Filling the Sub-Tank

1. Remove the sub-tank cap.
2. Fill the sub-tank with coolant until it reaches the FULL line.

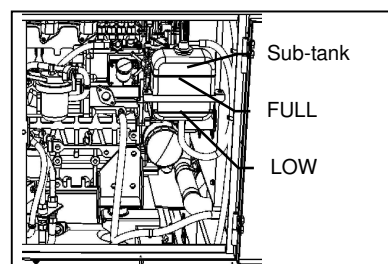

3 Re-attach the cap.

(2) Filling the Radiator

1 Remove the radiator plate.

2 Remove the radiator cap.

3 Fill with coolant through the filler neck until the radiator is full.

4 Re-attach and tighten the radiator cap.

5 Attach the radiator plate.

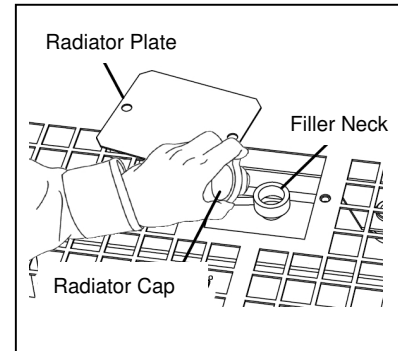

< Note >

- Be sure to only use long life coolant (LLC) for the aluminum radiator. The coolant should be mixed with good quality softened tap water, and contain anti-freezing and anti-rust components.
- The LLC mix ratio is 30% liquid and 70% water when shipped from the factory. (Isuzu Genuine LLC: Bescor LLC Super-Type E)
- Be sure to use the same LLC in the sub-tank.
- The mix ratio should be changed according to the ambient temperature but should remain between 30 and 50%.
- Do not increase the LLC mixture ratio unless necessary. Doing so could result in overheating or another fault/malfunction.

- When replenishing LLC, be sure to use the same brand as the LLC remaining in the radiator and sub-tank.
- Never use an LLC mixture of two different brands.
- Be sure to completely change every two years or 1,000 hours or less.
- LLC is a toxic substance. Wear rubber gloves and other protective wear when handling.
- If someone mistakenly ingests LLC, induce vomiting immediately and seek medical care.
- If LLC gets on skin or clothing, wash with water immediately.
- LLC is flammable. Store in a location where flame is prohibited and it cannot be accessed by children.
- Engine coolant could leak if the radiator is not completely tightened or there is a gap in the seating face. Always be sure to securely tighten the radiator cap.
- Do not add engine coolant past the FULL level line of the coolant sub-tank.

(3) Coolant Amount

(Unit: L)

Total Coolant Amount
9.7(1.1)

Value in parenthesis is the sub-tank capacity.

8-3. Checking the Fan Belt

(1) Fan Belt Tension

Press your finger against the middle of the fan belt. (approx. 98N) If the slack is 7 to 9 mm, the tension is normal.

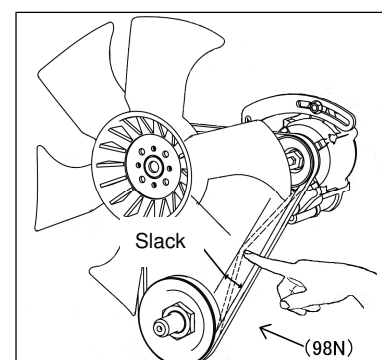

(2) Fan Belt Condition

Check the fan belt for damage and replace if any damage or other fault is found.

(3) Fan Belt Adjustment

- 1 Loosen the alternator installation bolts, pull the alternator out and adjust the fan belt tension.
- 2 Securely tighten the alternator installation bolts.
- 3 Check that the fan belt tension is correct.

(4) Replacing the Fan Belt

Request the authorized distributor where the generator was purchased to replace the fan belt.

< Note >

- Use of a loose or damaged fan belt could result in overheating or insufficient charging.
- Do not operate the generator if fan guard has been removed.

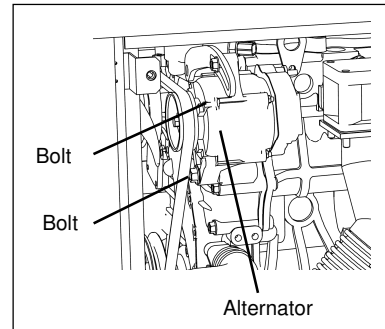

8-4. Checking the Fuel

⚠ CAUTION : FIRE

- This generator uses diesel fuel. Always be sure to stop the engine and not bring flames close when inspecting fuel or refueling. Wait until the engine has cooled before performing such procedures.

Check if there is a sufficient amount of fuel and add fuel if insufficient. The fuel meter on the control panel will only display the fuel level for the internal fuel tank.

< Note >

- Use Diesel fuel, ASTM D975 No.2-D in the event ambient temperature reaches down to -5°C .
- The fuel supply pump, injectors and other parts of the fuel system and engine can be damaged if any fuel or fuel additives are used other than those specifically recommended by the engine manufacturer.
- Always use the Diesel Fuel Strainer.
- Fill the fuel tank slightly less than the FULL tank level.

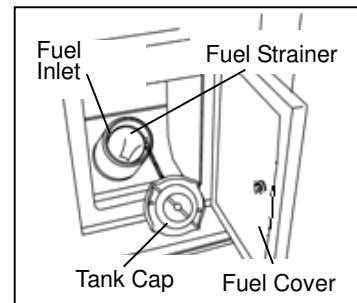

8-5. Checking for Fuel, Oil and Coolant Leaks

⚠ CAUTION : FIRE

- If fuel or oil is leaking, repair the leaking location before operating.

Open the check door and check for fuel, oil and coolant leakage from fuel piping connections and similar locations.

8-6. Checking the Battery

⚠ CAUTION : EYE/SKIN INJURY

- Wear rubber gloves and other protective wear to protect eyes, skin and clothing from the battery fluid which contains diluted sulfuric acid. If the battery fluid contacts eyes or skin, wash out immediately with a large amount of water. Be sure to receive medical treatment, especially if the fluid contacts the eyes.

⚠ CAUTION : EXPLOSION

- Never use or recharge the battery if the fluid level is below the minimum level.
- Do not create sparks or bring flame near the battery as it generates flammable gas.

- 1 Check the fluid level, and add distilled water when it is near the lower level until it reaches the upper level.
- 2 Check the terminals for looseness and tighten if loose.

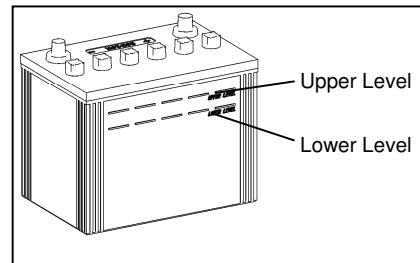

< Note >

- It is necessary to recharge the battery when the specific gravity of the battery fluid is 1.23 or less. Request the authorized distributor where the generator was purchased to recharge the battery.

■ Replacing the Battery

- 1 Remove the battery negative (-) cable. (Always be sure to remove the negative (-) side first.)
- 2 Remove battery hold-down clamp.
- 3 Remove the battery positive (+) cable.
- 4 Remove the battery.
* Install the battery by performing the above procedures in the reverse order.
(First connect the positive (+) cable of the replaced battery.)

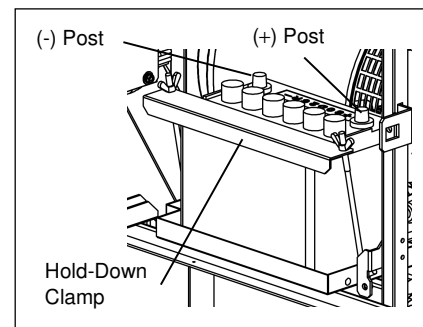

9. Operating Procedures

9-1. Initial Startup/Pre-Check

⚠ WARNING : EXHAUST GAS POISONING

- Do not operate the generator in poorly ventilated areas such as indoors or tunnels, as the exhaust gas of the engine contains substances that are harmful to human health.
- Do not direct exhaust fumes at bystanders or buildings.

⚠ WARNING : INJURY 

- Always be sure to check that the breaker on load side and switches for any equipment using the generator are at OFF before turning the breaker to ON. Also be sure to advise personnel on the load side that power will be turned on before operating the breaker.
- Close all doors and lock them during operation.

⚠ CAUTION : FIRE 

- Do not bring flammable items (such as fuel, gas and paint) or items that are highly combustible near the generator as the muffler, exhaust gas and other parts become extremely hot.
- Position this generator 1 m or more from walls or other hindrances, and on a level surface.

⚠ CAUTION : INJURY

- Do not operate the generator if it has been modified or any parts have been removed.
- Position the generator on a level stable surface so that it cannot slide or move in any manner.
- Before starting operation, always be sure to turn off all switches of equipment being used and breaker to OFF.

< Note >

- Check that the surrounding area is safe before starting the engine.
- When there are multiple workers who are working together, they must mutually signal each other before starting the engine.
- Do not use in an area with high temperature or humidity, or an area with a large amount of dust.
- Do not open any doors during operation. Operating with door open can negatively affect cooling effect, resulting in an equipment malfunction.
- Use ear protection if the level of noise is high. Failure to do so could result in hearing damage.
- Please be careful about a strong wind and the opening and shutting of the door at the sloping place enough. A door is open suddenly and is closed, and a finger might be sandwiched.

- 1 Turn the breaker on the operation panel to OFF.
- 2 Turn the Throttle switch to IDLING.
- 3 Turn the Starter switch to PREHEAT.
- 4 When the preheat lamp changes from lit up to off, immediately change the switch to START and start the engine.

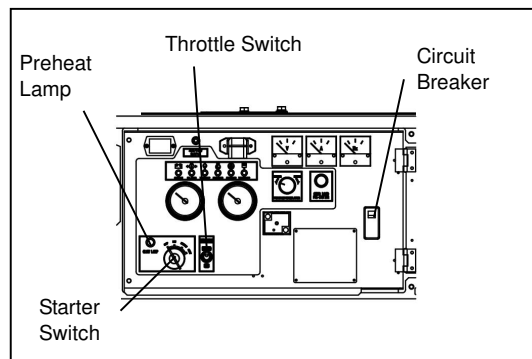

< Note >

- Pre-heating time depends on the coolant temperature, and completes in approximately 3 to 10 sec.
- Do not continuously operate the starter motor for 10 sec. or more.
- If repeating starter switch operation, wait 30 sec. or more between re-starting.
- Be aware that smoke might be generated when the engine is started.

- 5 After starting the engine, remove your hand from the starter switch.
- 6 Let engine idles for approximately for five minutes.
- 7 Turn the Throttle switch to RUN.

< Note >

- Change the Frequency Selector Switch if the frequency in the area where using this generator changes.
(Refer to "5-2.Meters,Throttle Lever,(3)Frequency Selector Switch")

↓8↓ Adjust the voltage regulator dial to the specified voltage.

50Hz Operation	200V [400V]
60Hz Operation	220V [440V]

* The values in brackets are for when set to 400/440V.

↓9↓ Turn the breaker to ON to start AC power delivery.

9-2. Procedures during Operation

(1) Checks after Startup

- Make sure that all meters and indicators are in normal status. (Refer to section "5. Equipment".)
- Check that there is no abnormal vibration or noise.
- Check that the exhaust gas color is normal. When operation is normal, the exhaust gas should be colorless or slightly bluish.

< Note >

- If abnormal, stop using this generator and request authorized distributor where the generator was purchased to repair the generator.

(2) Adjustment during Operation

During load operation, check the voltmeter and finely adjust voltage using the voltage regulator dial.

- Bleeding air from the fuel system when the engine stops due to running out of fuel
This generator is equipped with an automatic air bleeding mechanism. Perform the following procedures when the engine stops due to running out of fuel to easily bleed the air from the system.

↓1↓ Add fuel to the generator.

↓2↓ Turn the starter switch to RUN. Air bleeding is completed approximately in 30 sec.

< Note >

- Turn the throttle switch to IDLING, start the engine and check that the air is completely bled from the system. If air bleeding is not complete, engine rotation will not be stable. In that case, repeat the air bleeding operation.

9-3. Stopping Operation



CAUTION : BURNS





- Do not touch the engine and surrounding components immediately after stopping the engine as they are still hot.

↓1↓ Turn the switches and breakers on the load side to OFF.



↓2↓ Turn the breaker on the operation panel to OFF.

- 3 Turn the Throttle switch to IDLING.
- 4 The engine cools down for approximately 3 minutes.
- 5 Turn the starter switch to STOP.

9-4. Protective Functions

⚠ WARNING : INJURY  

- Do not open the check door during operation. Be careful of pinching or catching of moving parts such as the cooling fan and fan belt.
- Always be sure to stop the engine and remove the engine key when performing inspection or maintenance.

⚠ CAUTION : BURNS  

- Do not touch the engine and surrounding components immediately after stopping the engine as they are still hot.
- Hot steam gushes out from the coolant subtank if the generator overheats. Do not touch the coolant subtank.

This generator is equipped with functions to automatically stop operation when there is a fault/malfunction during operation, and one to warn the operator of the fault location by use of indicator lamps. Check the fault location when the engine is automatically stopped or an indicator lamp lights up to stop the engine.

Protection Feature List

No.	Abnormality	Action	Earth Leakage Relay Active	Breaker Trip	Engine Automatic Shutdown	Warning Indicator Flash	Cause
1	Monitor Lamp	High Water Temperature	–	–	○	○	Activates due to high water temperature in the engine Default 115°C
2		Low Oil Pressure	–	–	○	○	Activate due to low oil pressure in the engine Default 0.49 × 100 kPa
3		Battery Charge Insufficient	–	–	○	○	Activates in battery charge Impossible
4		Engine Overspeed	–	–	○	○	Engine speed is too fast (2070 min ⁻¹ or more)
5		Air Filter Clogging Up	–	–	–	○	The element is clogged making it necessary to clean or replace the element.
6		Water Separator Fluid Level	–	–	–	○	When the water separator is full of water.
7	Current Leakage	○	○	–	–	Activates in current leakage	
8	Overload	–	○	–	○	Activates in overload Flashes when at approx. 80% of rated output. Load rejection when the rated output is exceeded.	

* ○ indicates the automatic activation.

9-5. Connecting with External Fuel Tank

⚠ CAUTION : FIRE

- Always make sure that the engine is stopped when working on piping.
- Always be sure to wipe up any spilled fuel.
- After working on the piping, check that there is no fuel leakage.

1 Turn the 3way fuel valve lever to the “A” side.
(Position for using the internal tank.)

2 Remove the connecting hose from the 3way fuel valve.

3 Remove the plate.

4 Pass the fuel hose from the external tank through the external fuel ports and connect to the external tank fuel inlet/return of the 3way fuel valve.

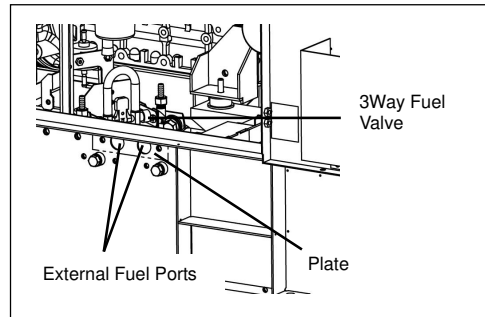

5 Turn the 3way fuel valve lever to the “B” side.
(Position for using the external tank.)

6 Bleed air from the external tank connecting hose. Fuel can be supplied from the external tank after completing the above procedures.

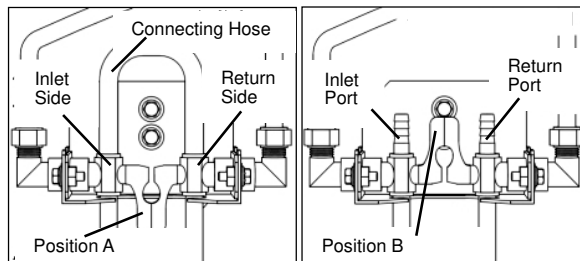

< Note >

- Protect the piping connecting the external fuel tank and this generator with corrugate tubing or similar in order to prevent interference between the generator internal parts and the external fuel ports.
- If using a hose for the piping, use oil-resistant hose with an internal diameter of 8 to 9 mm.
- Set the fuel level of the external fuel tank from 0 to 3 m from the underside of this generator. The fuel level of the external fuel tank being lower than this generator will result in poor engine operation or stoppage.
- Turn the 3way fuel valve lever to the “A” side in order to prevent fuel from flowing out from the external tank fuel inlet/return.
- Turn the lever completely as far as possible. If the lever is not completely pressed to either side, it might not be possible to supply fuel causing the engine to stop.
- Set the supply side so that it is 15 to 20 mm above the underside of the tank in order to prevent foreign material or water from being suctioned from inside the external fuel tank.
- Set the external fuel tank return side at the same height as the supply side in order to prevent poor engine operation due to air mixed in with the fuel.
- Refer to section “9-2 Procedures during Operation” for air bleeding.
- Some air may remain in hoses or pipes immediately after connecting the external fuel tank resulting in unstable engine speed and engine stoppage.
- Do not leave the generator unattended for unmanned operation until you have confirmed that the engine speed is stable.

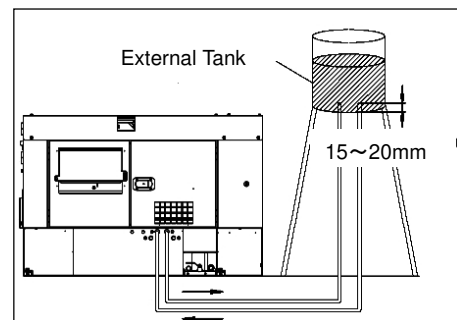

10. Inspection/Maintenance

WARNING : ELECTRIC SHOCK/INJURY

- Do not touch internal electric parts while the generator is operating.
- Do not open the check door during operation. Be careful of pinching or catching of moving parts such as the cooling fan and fan belt.
- Always be sure to stop the engine and remove the engine key when performing inspection or maintenance.
- Do not lift up using tie downs. Use of such could result in the generator falling.
- No persons should be under a suspended generator.

CAUTION : FIRE

- Always be sure to wipe up any spilled fuel or oil.

CAUTION : BURNS

- Do not touch the engine and surrounding components immediately after stopping the engine as they are still hot.
- Do not open the radiator cap immediately after stopping the engine. Do so will result in steam gushing out.
- Hot steam gushes out from the coolant subtank if the generator overheats. Do not touch the coolant subtank.

CAUTION : INJURY

- Personnel performing suspension work must wear protective gear such as helmets, safety shoes and gloves.
- Always be sure to use lifting hooks when suspending the generator, and raise it slowly at a completely vertical angle.

Perform periodic inspection and maintenance according to the following table in order to constantly maintain this generator in good working condition. Use the hour meter as a reference for the operating time.

< Note >

- All procedures except for pre-operation inspection should be performed by specialized technicians.
- Request authorized distributor where the generator was purchased to perform the procedures in the table with a “●”.
- Always be sure to use genuine parts or those indicated specifically for replacement parts.
- Use a container to catch fluid bled from this generator that is large enough to prevent the fluid from spilling on the ground.
Dispose of oil, fuel, coolant (LLC), filter, battery and other hazardous materials according to laws and regulations concerning industrial waste.
Contact authorized distributor where the generator was purchased if you have any inquiries regarding proper disposal.
- When check doors are open during maintenance, take measures so that unrelated personnel cannot accidentally come close to the generator. Close all doors and covers if you are going to be away from this generator.
- Please be careful about a strong wind and the opening and shutting of the door at the sloping place enough. When door is opened or closed suddenly, a finger might be sandwiched.

	Description	Daily	Every 100 hrs	Every 200 hrs	Every 400 hrs	Every 500 hrs	Every 800 hrs	Every 2,000 hrs	Remarks	
Engine	Each parts (Clean/Tightening)	○								
	Engine oil (Check/Add)	○								
	Engine oil (Replace)			○ 1 st time at 50 hrs						
	Oil filter (Replace)			○ 1 st time at 50 hrs						
	Coolant (Check/Add)	○								
	Coolant (Replace/Radiator Flush)							○ or 2 years		
	Exhaust color (Check)	○								
	Water separator (Check/Drain excess water and sediments)	○		○ (Drain)						
	Fuel filter/element (Clean/Replace)		○ (Clean)		○ (Replace)					
	Fuel tank (Drain water)			○						
	Water separator and Gauze filter (Clean)					○				
	Fuel tank (Clean)					●				
	Check for leaks (Fuel/Oil/Coolant)	○								
	Fuel/Cooling Water/Oil Hoses and Anti-Vibration Rubber (Replace)								● Every 2 years	
	Air cleaner element (Clean)		○ (Clean)							
	Air cleaner element (Replace)	once in 6 times cleaning or 1 year								
	Engine	Battery fluid level (Check/Add)	○							
		Battery gravity (Check)	○							
Fan belt tension (Check)		○								
Fan belt (Replace)						● or 2 years				
Radiator and fins (Clean)						●				
Valve clearance (Check/Adjust)							●			
Fuel injector (Check)									●	
Generator	Elimination of carbon in the exhaust pipe line and muffler			○						
	Indicators, Gauges Alarms (Check)	○								
	Operation check of Earth Leakage Relay	○								
	Grounding resistance check	○								
	Insulation test			○						

(1) Engine Oil Replacement

First Time	50 hours
Thereafter	Every 200 hours

- 1 Remove the oil filler cap.
- 2 After removing the oil drain plug and packing (a rubber seal is attached), drain the engine oil.
- 3 After the oil has been drained, reinsert the oil drain plug with new packing (a rubber seal is attached).
- 4 Add oil through the oil filler until it is at the maximum level while checking the oil level using the oil level indicator.
- 5 Attach the oil filler cap.

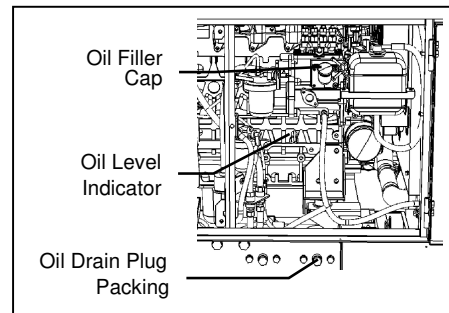

< Note >

- Refer to section “8-1. Checking Engine Oil” for engine oil replacement amounts and types.
- Replace the packing of the oil drain plug with new packing each time the oil is replaced.
- Packing part no.: 6C090-58961 (Kubota part no.)
- After reinserting the oil drain plug and shortly after starting the engine, be sure to always check that there is no oil leakage.

(2) Replacing the Oil Filter

First Time	50 hours
Thereafter	Every 200 hours

- 1 Drain the engine oil. (Refer to section “(1) Engine Oil Replacement”.)
- 2 Remove the oil filter using a filter wrench.
- 3 Spread a thin layer of oil on a new oil filter gasket.
- 4 Thread the oil filter by hand, and turn by hand (do not use a filter wrench) from when the gasket contacts the seal surface until it is securely tightened.
- 5 Add engine oil to the generator.
- 6 Shortly after starting the engine, always be sure to check that there is no oil leaking from the seal surface.

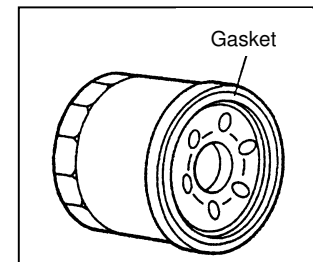

< Note >

- Request the authorized distributor where the generator was purchased to perform this procedure if you do not have a filter wrench.
- Oil filter part no.: 16414-32432 (Kubota part no.)

(3) Air Filter Element Cleaning/Replacement

Clean	100 hours
Replace	Every 400 hours

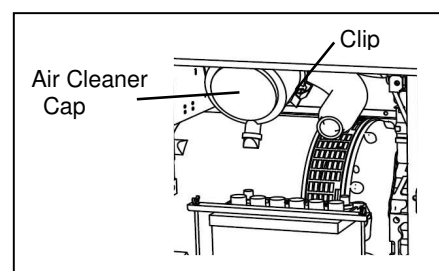

- 1 Remove the air cleaner clips and cleaner cap.
- 2 Remove the element.
- 3 Clean or replace the element. Replace by performing the above procedures in reverse order.

< Note >

- Always be sure to turn the cleaner cap in the direction indicated by the arrow.
- Replace the elements earlier if using in an excessively dusty location.
- Do not add oil as this generator uses a dry element.
- Clear foreign material by pinching the vacuator valve once a week in normal operating conditions or daily if operating in a location that is excessively dirty or dusty. Wipe away any dirt or moisture that has adhered to the parts.
- Never touch the elements for any reason except cleaning.
- Element part no.: R1401-42271 (Kubota part no.)

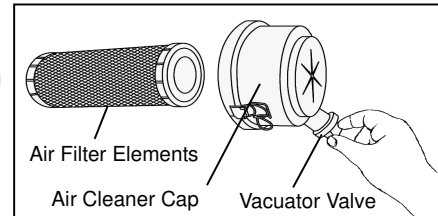

■ **Cleaning the air filter element**

If dry dust is adhering : Blow compressed air from inside the element.

If carbon or oil is adhering : Replace with new parts.

(4) Draining Water from the Water Separator

Check	Daily
Clean	Every 200 hours

Drain water when the float (red) inside the cup is at the water draining position.

- 1 Close the fuel valve.
- 2 Loosen the faucet and then loosen the air bleeder plug.
- 3 After water has been drained, tighten the faucet and air bleeder plug.
- 4 If foreign material is adhering to the gauze filter in the cup, remove the cup, float and gauze filter, and clean by blowing compressed air from the inside of the gauze filter.
- 5 Reassemble the gauze filter, cup and float to their original locations.

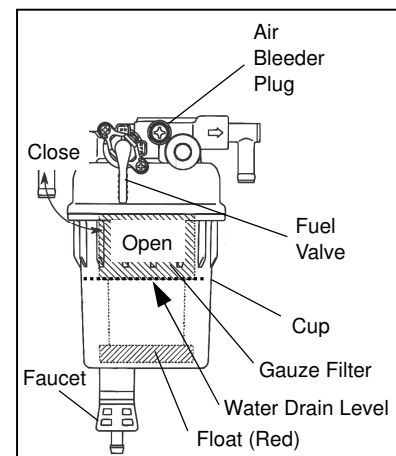

< Note >

- When attaching the cup, check that there is no foreign material adhering to the O-ring.
- After attaching, open the fuel valve, and be sure to always start the engine and check that there is no fuel leakage.
- If water is accumulate in the cup, draining water from the fuel tank. (Refer to section “(6) Draining Water from the Fuel Tank”.)

(5) Fuel Filter Cleaning/Replacement

Cleaning	Every 200 hours
Replace	Every 400 hours

1. Close the fuel valve.
2. Turn the retainer ring to the left and remove the cup and element.
3. Remove any water or foreign material from the cup and clean the element using compressed air. (Or replace the element.)
4. Install in the reverse order of removal.

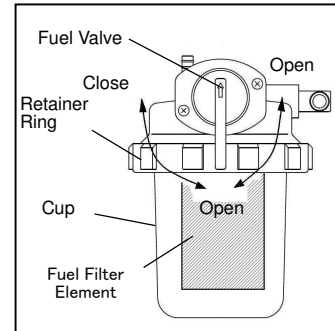

< Note >

- When attaching the cup, check that there is no foreign material adhering to the O-ring.
- After attaching, open the fuel valve, and be sure to always start the engine and check that there is no fuel leakage.
- Be sure to wipe away any fuel that has spilled out of the piping when removing the filter.
- Fuel filter element part no.: 15521-43161 (Kubota part no.)

You can install a large fuel filter to this generator. To install, first remove the standard fuel filter from the stay and install the large fuel filter.

- Large fuel filter part no.: 1K947-43012 (Kubota part no.)
- Large fuel filter element part no.: 1K947-43171 (Kubota part no.)

(6) Draining Water from the Fuel Tank

Drain Water	Every 200 hours
-------------	-----------------

1. Remove the fuel drain plug and packing (with rubber seal).
2. After the water has been drained, reinsert the fuel drain plug with new packing (with rubber seal).

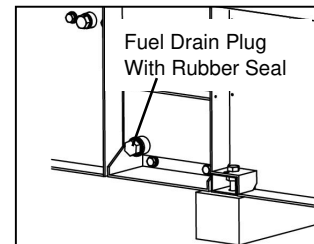

< Note >

- Replace the packing of the fuel drain plug with new packing each time the water is drained.
- Packing part no.: V106-000110
- After reinserting the fuel drain plug, be sure to always check that there is no fuel leakage.

(7) Coolant Replacement

Replace	Every 2year or Every 1000 hours
---------	---------------------------------

1. Remove the radiator plate.
2. Remove the radiator cap.
3. Remove the coolant drain plug and packing.
4. After the coolant has been drained, reinsert the coolant drain plug with new packing.
5. Remove the subtank and flush the coolant from the subtank.
6. Reattach the subtank to its original position and fill with coolant until it reaches the FULL level.

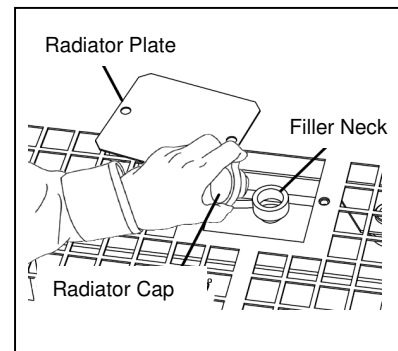

- 7. Fill the radiator with coolant until it reaches the filler neck.
- 8. Re-attach and tighten the radiator cap.
- 9. Attach the radiator plate.

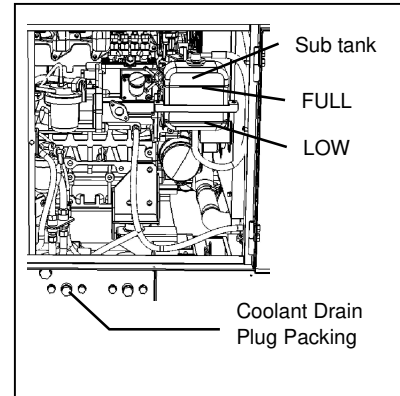

< Note >

- Refer to section “8-2. Checking Coolant” for coolant information.
- Replace the packing of the coolant drain plug with new packing each time the coolant is changed.
- Packing part no.: 6C090-58961 (Kubota part no.)
- After reinserting the coolant drain plug and shortly after starting the engine, be sure to always check that there is no coolant leakage.

(8) Elimination of carbon in the exhaust pipe line and muffler

⚠ WARNING : EXHAUST GAS POISONING 

- Do not operate the generator in poorly ventilated areas such as indoors or tunnels, as the exhaust gas of the engine contains substances that are harmful to human health.
- Do not direct exhaust fumes at bystanders or buildings.

⚠ WARNING : INJURY 

- Always be sure to check that the breakers on load side and switches for any equipment using the generator are at OFF before turning the breaker to ON. Also be sure to advise personnel on the load side that power will be turned on before operating the breaker.
- Close all doors and lock them during operation.

⚠ CAUTION : FIRE 

- Do not bring flammable items (such as fuel, gas and paint) or items that are highly combustible near the generator as the muffler, exhaust gas and other parts become extremely hot.
- Position this generator 1 m or more from walls or other hindrances, and on a level surface.

⚠ CAUTION : INJURY

- Do not operate the generator if it has been modified or any parts have been removed.
- Position the generator on a level stable surface so that it cannot slide or move in any manner.
- Before starting operation, always be sure to turn off all switches of equipment being used and all breakers to OFF.

Clean	Every 200 hours
-------	-----------------

Accumulation of carbon (soot, unburned fuel) in the exhaust pipe line and muffler could cause only a system derates or an engine fault occurs. To destroy the soot and unburned fuel, run the unit at rated power for some period of time until the exhaust gas become mostly colorless every 200 hours operation time. The carbon will be easier to be generated

when the unit operates at less than 30% of rated power. In this case, perform the above procedures at shorter interval time.

< Note >

- When the unit operates at rated power, accumulation of carbon in the exhaust pipe line and muffler might lead to back fire incident. Do not bring flammable items that are highly combustible near the generator.

11. Long-Term Storage

⚠ WARNING : INJURY 

- Before performing any equipment check or maintenance, stop the engine, and remove the engine key. A person performing the maintenance should always keep the key.

⚠ CAUTION : FIRE 

- Always be sure to wipe up any spilled fuel or oil.
- Allow the generator to cool before covering with the protective cover.

⚠ CAUTION : BURNS 

- Do not touch the engine and surrounding components immediately after stopping the equipment, while temperature can reach extremely high.

(1) Storage Procedures

Perform the following maintenance procedures before storing this generator if it is not going to be used for two months or more.

- 1 Remove the battery.
(Refer to section “**8-7. Checking the Battery Replacing the Battery**”.)
- 2 Replace the engine oil.
(Refer to section “**10. Inspection/Maintenance (1) Engine Oil Replacement**”.)
- 3 Drain the fuel from the fuel tank and filter.
(Refer to section “**10. Inspection/Maintenance (5) Fuel Filter Cleaning/Replacement**”.)
(Refer to section “**10. Inspection/Maintenance (6) Draining Water from the Fuel Tank**”.)
- 4 Remove the starter key and store in a secure location.
- 5 Clean up all generator components, and store in a dry and dust-free location. Also cover when storing so that rain cannot enter through the suction or exhaust ports.

< Note >

- Adjust the fluid of the removed battery to the appropriate level and recharge approximately every month.

(2) Double-Stacking Procedures

WARNING : INJURY

Always be sure to observe the following items when double stacking this generator in a warehouse or similar location.

- Check that the Top cover of this generator is not dented, and that bolts are not loosen or missing.
- Set in a location with a flat hard floor capable of withstanding the double-stacking weight.
- Always be sure to use lifting hooks when lifting this generator.
- Insert wood ties of the same size and that are wider than this generator between each generator, and set another generator on top of the ties.
- Never stack more than two levels, and do not set a generator on top that is larger in weight/size than that on the bottom.
- Do not operate the generator when it is double stacked.

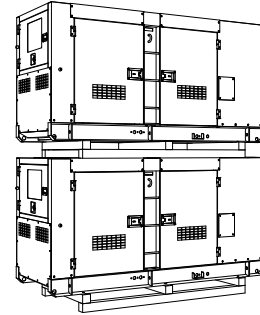

12. Troubleshooting

WARNING : ELECTRIC SHOCK/INJURY

- Do not touch output terminals or internal electric parts while the generator is operating.
- Close all doors and place locks during operating this equipment, to avoid injuries by unintentionally touching cooling fan and fan belt.
- Before performing any equipment check or maintenance, stop the engine, and remove the engine key. A person performing the maintenance should always keep the key.

CAUTION : FIRE

- Never allow flame to come close to the generator.

CAUTION : BURNS

- Do not touch the engine and muffler after stopping the engine while temperature can reach extremely high.

Inspect this generator when operation is poor to determine the fault/malfunction. Request the authorized distributor where the generator was purchased to perform maintenance if you cannot find any faults/malfunctions during inspection.

	Problem	Suspected cause	Action
Engine does not start	Starter motor does not drive or speed is low.	<ol style="list-style-type: none"> 1. Battery output is weak 2. Battery is deteriorated 3. Battery terminal is OFF or loose 4. Battery terminal is corroded 5. Starter switch or relay is defective 6. Starter motor is defective 7. ECU(Engine Controller) is defective Battery Isolator is OFF	<ol style="list-style-type: none"> 1. Check / battery liquid/ or Charge 2. Change battery 3. Fix / Tighten terminal 4. Clean terminal 5. Ask our distributor to repair 6. Ask our distributor to repair 7. Ask our distributor to repair
	Starter motor drives but engine does not start	<ol style="list-style-type: none"> 1. Fuel is insufficient 2. Fuel filter is clogged 3. Gauze filter is clogged 4. Water is interfused in fuel line 5. Air is interfused in fuel line 6. Poor piping connection to external fuel tank 7. Fuel tank selector lever (3-way valve) position is wrong 8. Fuel cut solenoid (motor) does not work 9. Fuel pump defective 	<ol style="list-style-type: none"> 1. Add fuel 2. Clean/Change fuel filter 3. Clean/Change gauze filter 4. Drain water in water separator, fuel filter or fuel tank 5. Extract the air 6. Check piping connection 7. Check lever (3-way valve) 8-1. Check/Change fuse 8-2. Check/Change fuel cut Solenoid 9-1. Check/Change fuse 9-2. Check/Change fuel pump
	<Ambient temperature falls down below zero>	<ol style="list-style-type: none"> 1. Fuel is frozen 2. Water in fuel line is frozen 3. Pre-heater is defective 	<ol style="list-style-type: none"> 1. Use winterized fuel 2. Drain water in fuel line 3. Ask our distributor to repair
Engine starts but stalls immediately	<ol style="list-style-type: none"> 1. Fuel filter is clogged 2. Gauze filter is clogged 3. Water is interfused in fuel line 4. Air is interfused in fuel line 5. Poor piping connection to external fuel tank 6. Air filter element is clogged 7. Lubricant oil is insufficient 8. Emergency operation/Fault detection 	<ol style="list-style-type: none"> 1. Clean/Change fuel filter 2. Clean/Change gauze filter 3. Drain water in water separator, fuel filter or fuel tank 4. Extract the air 5. Check piping connection 6. Check/Change air filter element 7. Supply lubricant oil 8. Ask our distributor to repair 	
Engine oil pressure is low	<ol style="list-style-type: none"> 1. Lubricant oil is insufficient 2. Oil filter is clogged 3. Oil Pressure switch is defective 4. Wrong oil is used 	<ol style="list-style-type: none"> 1. Supply lubricant oil 2. Change oil filter 3. Ask our distributor to repair 4. Change to proper kind and viscosity oil 	

Problem	Suspected cause	Action
Overheated	<ol style="list-style-type: none"> 1. Engine thermostat is defective 2. Water temp sensor is defective 3. Water temp meter is defective 4. Fan belt tension is weak 5. Coolant is insufficient 6. Radiator core is clogged 	<ol style="list-style-type: none"> 1. Ask our distributor to repair 2. Ask our distributor to repair 3. Ask our distributor to repair 4. Check/Adjust fan belt 5. Check/Supply coolant 6. Clean radiator core
Black smoke comes out from muffler	<ol style="list-style-type: none"> 1. Air filter element is clogged 2. Fuel injection nozzle is defective 3. Improper fuel is used 	<ol style="list-style-type: none"> 1. Check/Change air filter element 2. Ask our distributor to repair 3. Change to clean fuel
White smoke comes out from muffler	<ol style="list-style-type: none"> 1. Too much or too little oil to cylinder 2. Water is interfused in fuel line 3. Fuel injection nozzle is defective 4. Coolant temperature is too low 5. Engine thermostat is defective 	<ol style="list-style-type: none"> 1. Ask our distributor to repair 2. Drain water in water separator, fuel filter or fuel tank 3. Ask our distributor to repair 4. Warm-up driving is needed 5. Ask our distributor to repair
Pointer (hand) does not move in voltage meter	<ol style="list-style-type: none"> 1. Voltage meter is defective 2. AVR is defective 3. Disconnected circuit, loose terminal or departed 4. Initial exciter is defective 5. Alternator is defective 6. AVR protective device operation 	<ol style="list-style-type: none"> 1. Ask our distributor to repair 2. Ask our distributor to repair 3. Ask our distributor to repair 4. Ask our distributor to repair 5. Ask our distributor to repair 6. Replace AVR fuse
Pointer (hand) does not goes up to the rated voltage	<ol style="list-style-type: none"> 1. Voltage meter is defective 2. AVR is defective 3. Voltage regulator dial is defective 4. Frequency is low 	<ol style="list-style-type: none"> 1. Ask our distributor to repair 2. Ask our distributor to repair 3. Ask our distributor to repair 4. Ask our distributor to repair
Pointer exceeds the rated voltage	<ol style="list-style-type: none"> 1. Voltage meter is defective 2. AVR is defective 3. Improper load cable connection 	<ol style="list-style-type: none"> 1. Ask our distributor to repair 2. Ask our distributor to repair 3. Correctly set the connection location to the output terminal
The voltage drops drastically when connecting to load	<ol style="list-style-type: none"> 1. AVR is defective 2. Unbalanced loads sharing to each terminal 3. The current of the used equipment exceeds the rated current Loads total exceeds the rated current 4. Over laod 5. AVR protective device operation 6. Frequency selector is wrong setting 	<ol style="list-style-type: none"> 1. Ask our distributor to repair 2. Balance the loads sharing to each terminal 3. Change to a device with an available capacity 4. Decrease the laods to meet the rated output 5. Replace AVR fuse 6. Set to properfrequency
Cannot turn the breaker to ON	<ol style="list-style-type: none"> 1. The breaker positions at between ON and OFF 2. Short circuit on the load 3. Earth Leakage Relay operates 	<ol style="list-style-type: none"> 1. Once turning the lever to OFF, turn it to ON 2. Check the load circuit 3. Repair the earth leakage location

13. Generator Circuit Diagram

(1) 200/220V

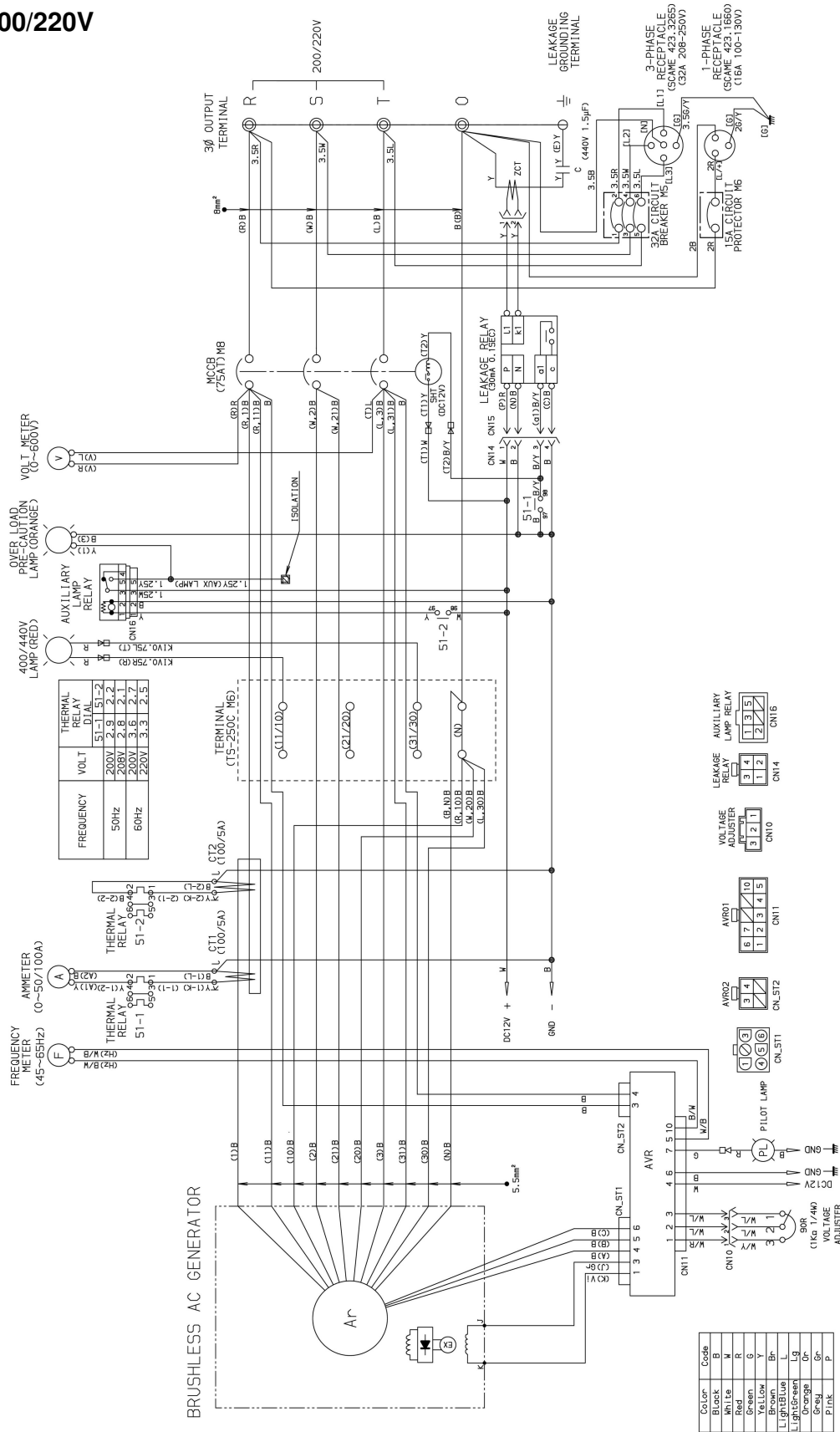

(2) 400/440V

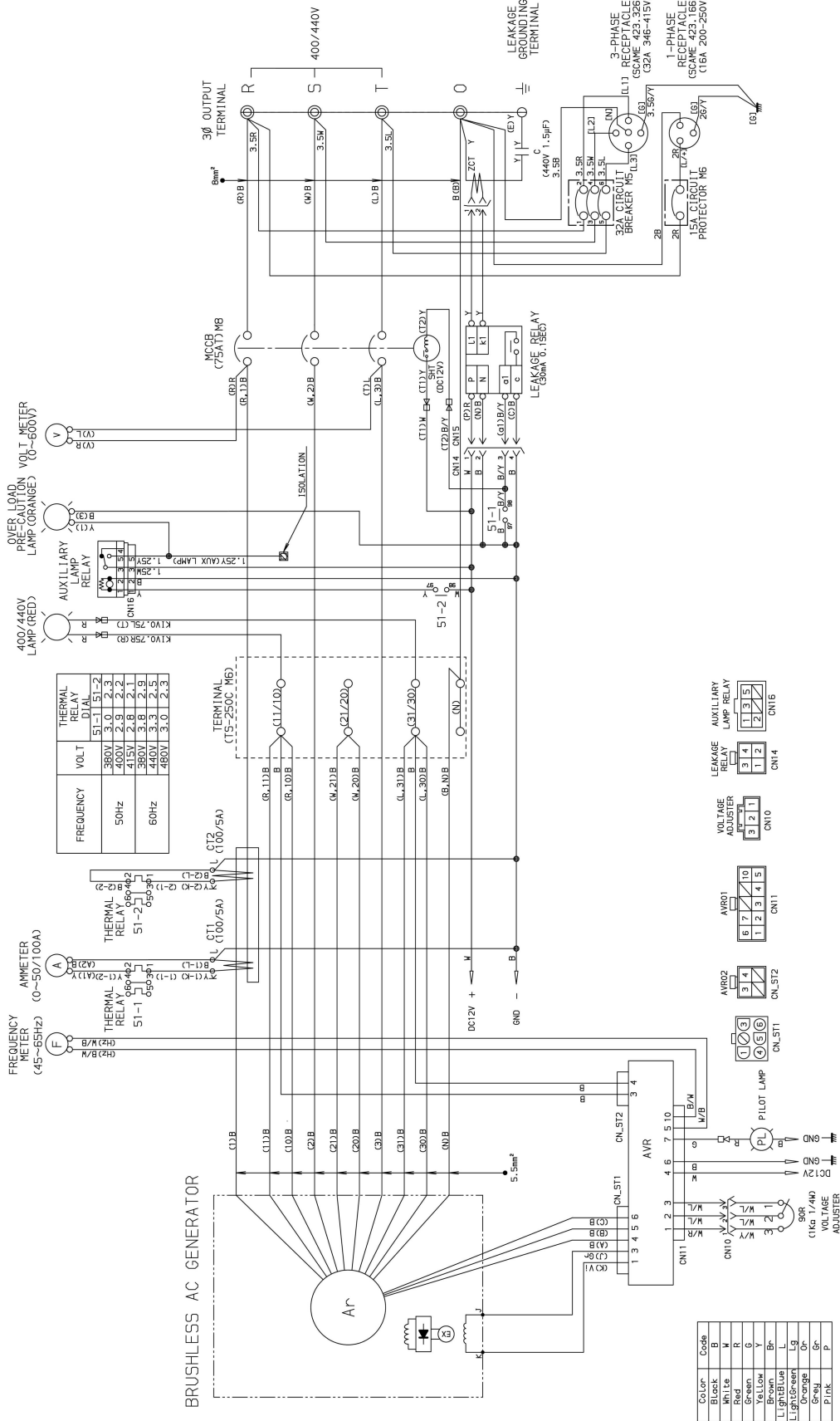

14. Engine Electrical Circuit Diagram

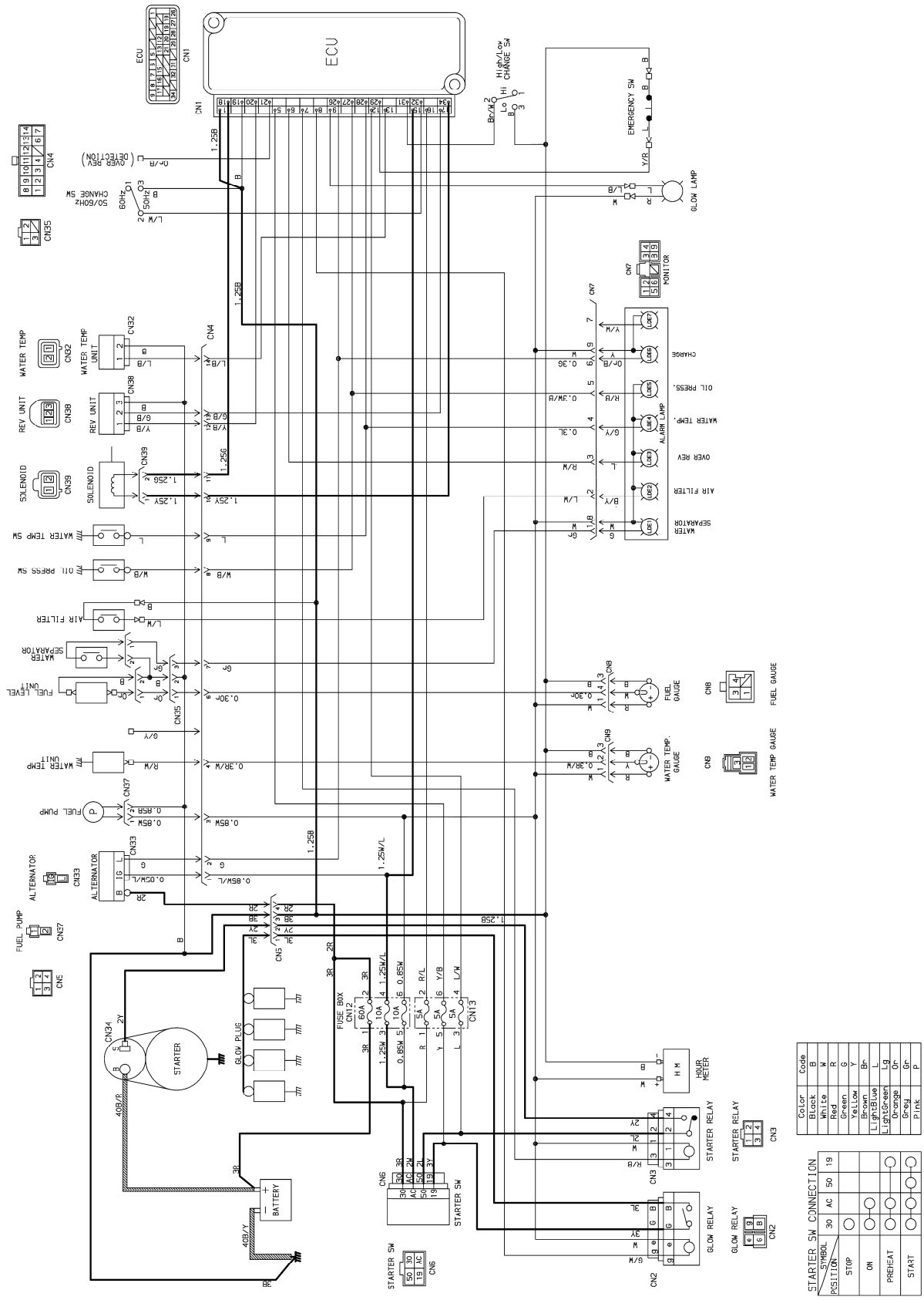

Color	Code
Black	B
White	M
Red	R
Green	G
Yellow	Y
Blue	B-
Light Green	Lg
Orange	Or
Green	Gr
Pink	P

STARTER SW CONNECTION	30	AC	50	19
STOP	○	○	○	○
ON	○	○	○	○
PREHEAT	○	○	○	○
START	○	○	○	○

YAMABIKO CORPORATION

7-2 SUEHIROCHO 1-CHOME, OHME, TOKYO 198-8760, JAPAN
PHONE: 81-428-32-6118. FAX: 81-428-32-6145.

shindaiwa[®]