



OWNER'S AND OPERATOR'S MANUAL

Diesel Engine Generator & Welder

DGW310MC

Vertical, Water-Cooled 4-Cycle Diesel Engine



CAUTION

Do not operate the Generator/Welder, or any other appliance, before you have read and understood the instructions for use and keep near for readily use.

DGW310MC/RS

X750-021 46 0

X750803-570 0

Introduction

Thank you for purchasing Shindaiwa Sound Proof Diesel Engine Generator & Welder.

- This user manual was created to ensure the safe operation of this equipment. Therefore, the manufacturer of this equipment strongly recommends that the user follow the instructions herein, to avoid unnecessary accidents and repairs.
- Please operate this equipment after thoroughly reviewing and understanding the contents of this manual. Do not operate the equipment while under the influence of alcohol, medication, or other drugs, or while fatigued.
- Must be compliant with all applicable regulations for the area in which the equipment is operated.
- Please attach this manual and explain how to operate and have them read this manual, if the equipment will be sub-leased.
- Please store this manual near the equipment for easy reference. Replace damaged or missing the manual with new manual from authorized distributor.
- For service, contact the authorized distributor. Please be prepared to give them the model name and serial number.
- Observe the relevant environmental protection regulations when disposing of equipment.

■ Following convention will be used throughout the manual to indicate the degree of cautions.

 **Danger** : Can cause serious injuries or death.

 **Caution** : Can cause minor injuries or damage to the equipment or other properties.

<Caution> : Other types of caution.

- Even some of the items noted in 『 **Caution** 』 may lead to serious injuries. Please read all item and follow all the safety guidelines.

Table of Contents

| | |
|---|----|
| 1. Safety Guidelines | 2 |
| 2. Specifications | 5 |
| 3. Usage | 5 |
| 4. Names of Parts | 6 |
| 5. Equipment | 8 |
| 5-1. Eco Welding | 8 |
| 5-2. Display | 8 |
| 5-3. Monitor Lamp | 8 |
| 5-4. Remote Control(Optional) | 9 |
| 5-5. Earth Leakage Relay and Grounding | 10 |
| 5-6. Auto Idle Feature | 12 |
| 5-7. AC Voltage Adjustment Dial | 12 |
| 5-8. Frequency Change | 12 |
| 6. Initialization and Pre-operation check | 13 |
| 6-1. Checking Engine Oil | 13 |
| 6-2. Checking Coolant/Water | 13 |
| 6-3. Checking Fuel | 14 |
| 6-4. Checking Fuel, Engine Oil and Water Leakage | 15 |
| 6-5. Checking Battery | 15 |
| 7. Operation the Engine | 16 |
| 7-1. Starting | 16 |
| 7-2. Stopping | 17 |
| 8. Welding Operation | 17 |
| 8-1. Selection-Welding Cable | 17 |
| 8-2. Polarity | 18 |
| 8-3. Connection-Welding Cable | 18 |
| 8-4. Welding | 19 |
| 9. Generator Operation | 20 |
| 9-1. Output Range | 20 |
| 9-2. Output Limitation | 20 |
| 9-3. Operation | 21 |
| 10. Simultaneous Use of Welding and Generating | 22 |
| 11. Inspection and Maintenance | 23 |
| 12. Long-term Storage | 27 |
| 13. Troubleshooting | 28 |
| 14. Engine Wiring Diagram | 30 |
| 15. Generator Wiring Diagram | 31 |

1. Safety Guidelines

Danger : Suffocation from exhaust fume

- Exhaust fume from the engine contains many elements harmful to human. Do not operate this equipment in poorly ventilated area, such as inside a room or in a tunnel.

Danger : Electric Shock

- Close all doors and place locks during operation.
- Do not touch the output terminals or external body while the unit or your body is wet.
- Do not insert metal objects (such as pin or wire) into plug-in receptacles.
- Do not touch wiring or electric parts inside the equipment during operation.
- Before connecting or disconnecting a plug from output receptacle, always turn the circuit breaker to OFF position.
- Before connecting or disconnecting a welding cable from output terminals, stop the engine, and remove the engine key.
- Before performing any equipment check or maintenance, stop the engine, and remove the engine key. A person performing the maintenance should always keep the key.

Danger : Electromagnetic Interference

- Person with a pacemaker of the heart, do not approach the equipment and welding around the work site during work. May adversely affect the operation of the pacemaker.

Danger : Injuries

- Close all doors and place locks during operating this equipment, to avoid injuries by unintentional contact with cooling fan and fan belt.

Caution : Suffocation from exhaust fume

- Do not redirect the exhaust fume toward pedestrians or building.

Caution : Suffocation from welding fume

- Be sure to wear a fume proof mask in operation, because welding fume contains poisonous gas and dust. Pay attention to the airflow direction and sufficient ventilation also in order to prevent from inhaling the fume.

Caution : Injuries to eyes and skin

- Be sure to wear spark protection glass (es), long-sleeve shirts, gloves, etc. in order to protect eyes and skin from harmful spark in welding.
- Battery fluid contains diluted sulfuric acid. Avoid contact with eyes, skin or on clothing. If the acid comes in contact, especially with eyes, flush with a lot of water, and contact your physician immediately.

Caution : Electric shock

- Do not flush water onto the equipment nor operate it in the rain.

⚠ Caution : Explosion

- Do not use the equipment or charge the battery, in the case the battery fluid level is lower than the LOWER level.
- Battery may emit some combustible gas, so keep it away from fire and sparks.

⚠ Caution : Fire

- The equipment uses Diesel Oil as a fuel. When inspecting the equipment or refueling, always stop the engine and keep away from fire. Moreover, always wait until the engine cools down before refueling.
- Always wipe any drip of Diesel fuel or lubrication oil. Do not use this equipment when leakage is found. Repair the equipment before use.
- Temperature around muffler and exhaust can get extremely high. Keep any inflammable items (such as fuel, gas, paint, etc.) away from the equipment.
- Keep any inflammable items and easily burning items away from the place in welding, because welding splashes spatters.
- Always operate this equipment on flat surface and, at least 1 meter away from any objects (wall, box, etc.).
- Do not connect AC output to any indoor wiring.
- Always wait until the equipment cools down, before placing any covering materials for storage.

⚠ Caution : Burns

- Do not open the radiator cap while operating this equipment or immediately after stopping the equipment, to avoid sustaining burns from hot vapor.
- Do not touch the engine and muffler during operation and immediately after stopping the equipment, for the temperature could reach extremely high temperature.
- When checking engine oil or changing oil, always stop the engine, and wait until the engine cools down. If you open either the oil gauge or the oil plug during operation, hot oil may cause some injury.
- Be sure to wear leather gloves, apron, shoe covers, eye protection glass(es) (mask), safety shoes, safety cap, and long sleeve shirts, because welding splashes spatters.
- Do not open the side door during operation and immediately after stopping the equipment, because some parts/components (flexible tube, resistors, etc.) can reach very high temperature inside the equipment.

⚠ Caution : Injuries

- When lifting the equipment, always use a lifting lug. Do not lift a handle, for it may cause equipment to drop due to handle breaking off.
- When carrying the equipment by trucks, fix it strongly to keep the equipment from sliding.
- Always place the equipment on a flat and stable surface, to keep the equipment from sliding.
- When starting the engine, turn off the connected equipment and set the circuit breaker to OFF position.
- Do not move the equipment during operation.
- When performing equipment check and maintenance, always stop the engine.
- Do not operate the equipment, if the equipment is being modified or if the parts are removed.

■ Location of Warning labels

When any warning label becomes unreadable or damaged, place a new label on the appropriate location.

When ordering a new label, use the following part number.

- | | |
|---------------------------------|---------------------|
| ① Suffocation from exhaust fume | (No. X505-004 90 0) |
| ② Suffocation from welding fume | (No. X505-004 91 0) |
| ③ Electric Shock | (No. X505-004 92 0) |
| ④ Electric Shock | (No. X505-004 93 0) |
| ⑤ Injuries | (No. X505-004 94 0) |
| ⑥ Fire | (No. X505-004 88 0) |
| ⑦ Burns | (No. X505-004 95 0) |
| ⑧ Burns | (No. X505-004 96 0) |

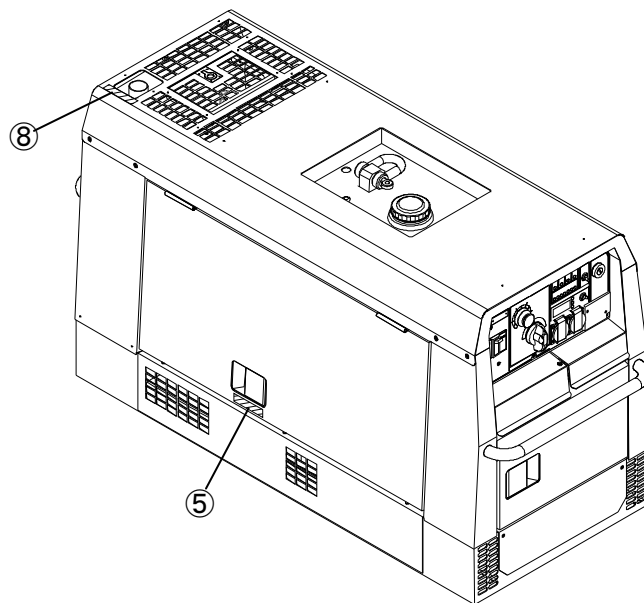
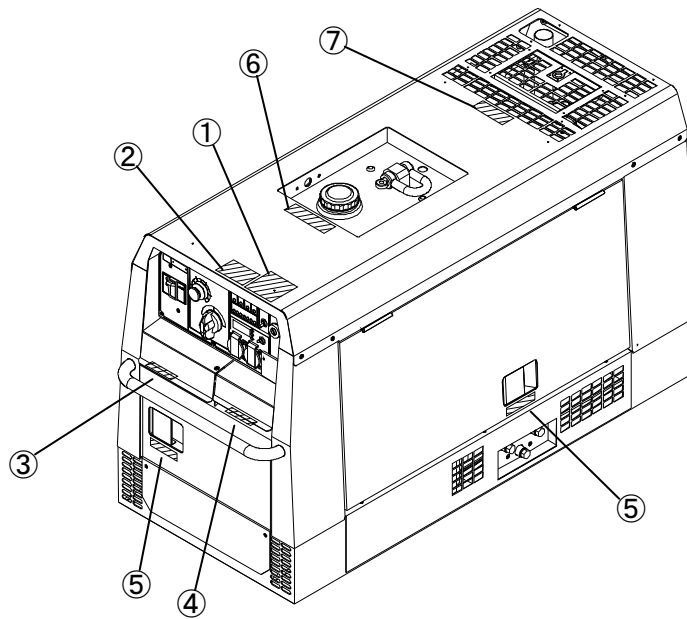

2. Specifications

| | | | | |
|------------------------|--------------------------------------|--|---------------|--|
| Model | | DGW310MC/RS | | |
| Generating Method | | Rotating Field | | |
| Welding DC Generator | Rated Current (A) | 260/280 | | |
| | Rated Voltage (V) | 30.4/31.2 | | |
| | Duty Cycle (%) | 100 | | |
| | Rated Speed (min ⁻¹) | 3000/3600 | | |
| | No Load Voltage (V) | MAX 85 | | |
| | ECO | Current Adj. Range (A) | 30~160 | |
| | | Welding Rod (mm) | 2.0~4.0 | |
| | NORMAL | Current Adj. Range (A) | 35~280/45~310 | |
| Welding Rod (mm) | | 2.0~6.0 | | |
| AC Generator | Rated Frequency (Hz) | 50/60 | | |
| | Rated Speed (min ⁻¹) | 3000/3600 | | |
| | Phase | 1-Phase | 3-Phase | |
| | Rated Voltage (V) | 230/250 | 400/440 | |
| | Rated Current (A) | 15Ax2 | 14.3/13.0 | |
| | Power Factor | 1.0 | 0.8 | |
| | Rated Output (kVA) | 6.9/7.5 | 9.9 | |
| | Rating | Continuous | | |
| Engine | Model | Kubota D722 | | |
| | Type | Water-Cooled 4-Cycle Diesel Engine | | |
| | Displacement (L) | 0.719 | | |
| | Rated Output (kW/min ⁻¹) | 11.7/3000 | 14.0/3600 | |
| | Fuel | ASTM No.2 Diesel Fuel or Equivalent | | |
| | Lubricant Oil | API Class CD or Higher | | |
| | Lubrication Oil Volume (L) | 3.8 (Effective 1.4) | | |
| | Cooling Water Volume (L) | 3.0 (Sub Tank Capacity 0.6 L included) | | |
| | Starting Method | Starter Motor | | |
| Battery | 46B24L(Japan Industrial Standard) | | | |
| Fuel Tank Capacity (L) | 37 | | | |
| Dimension | Length (mm) | 1410 | | |
| | Width (mm) | 566 | | |
| | Height (mm) | 760 | | |
| Dry Weight (kg) | 333 | | | |
| Full Weight (kg) | 377 | | | |

3. Usage

- Arc Welding
- Power Source Electric Tools and Home Appliances
- Power Source for Lights

⚠ Caution : Damage to the equipment or other properties

- Do not use other than the above purposes.
- Whenever connecting to use medical equipment or appliances, be sure to consult with the medical equipment company, doctor or hospital personnel.

4. Name of Parts

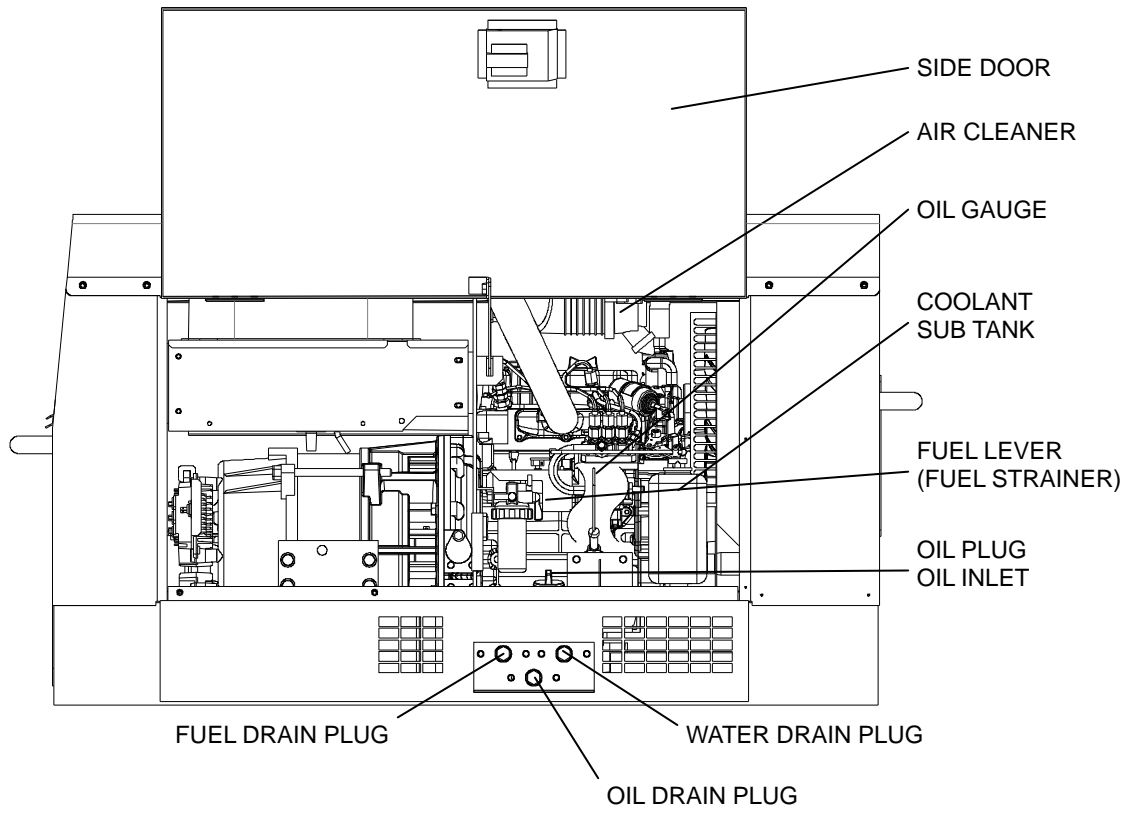
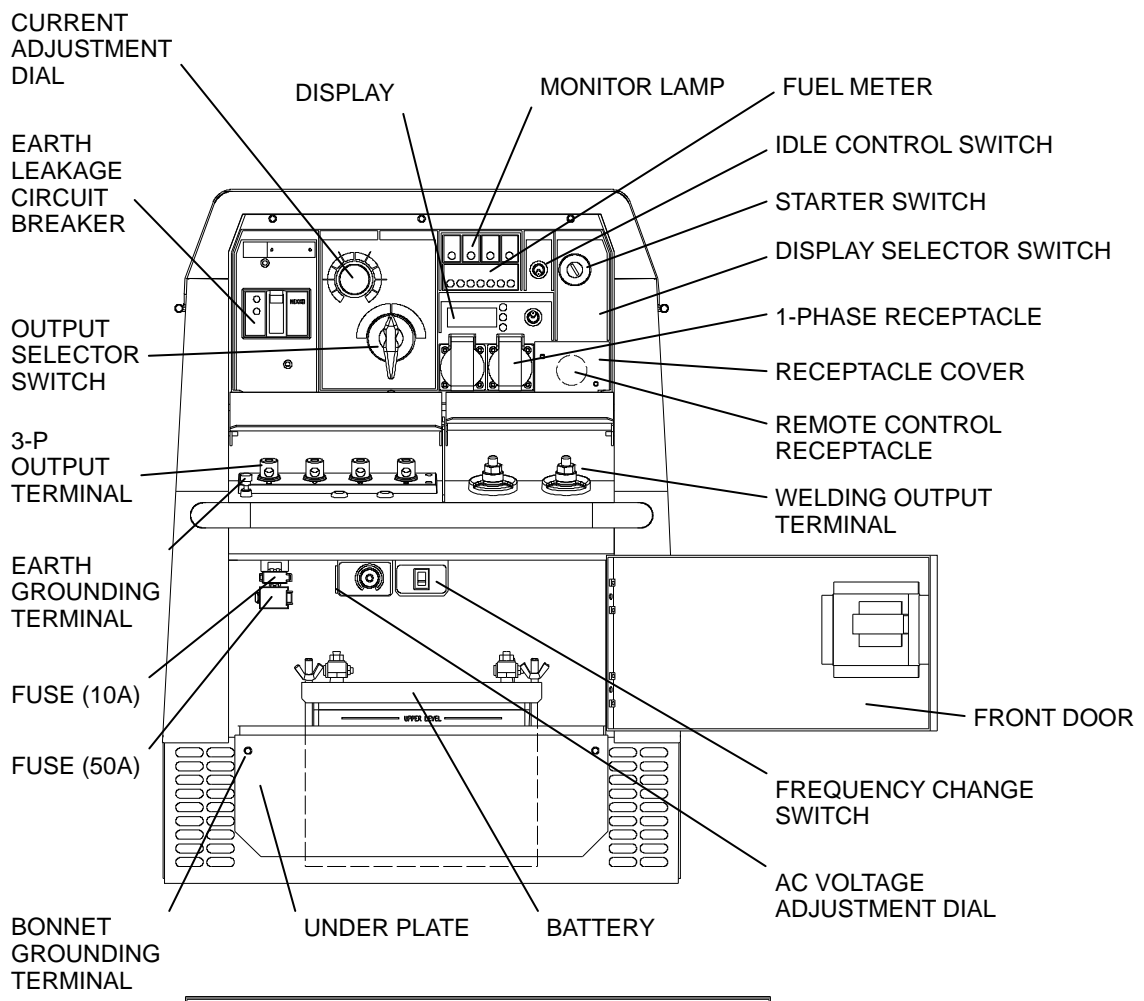

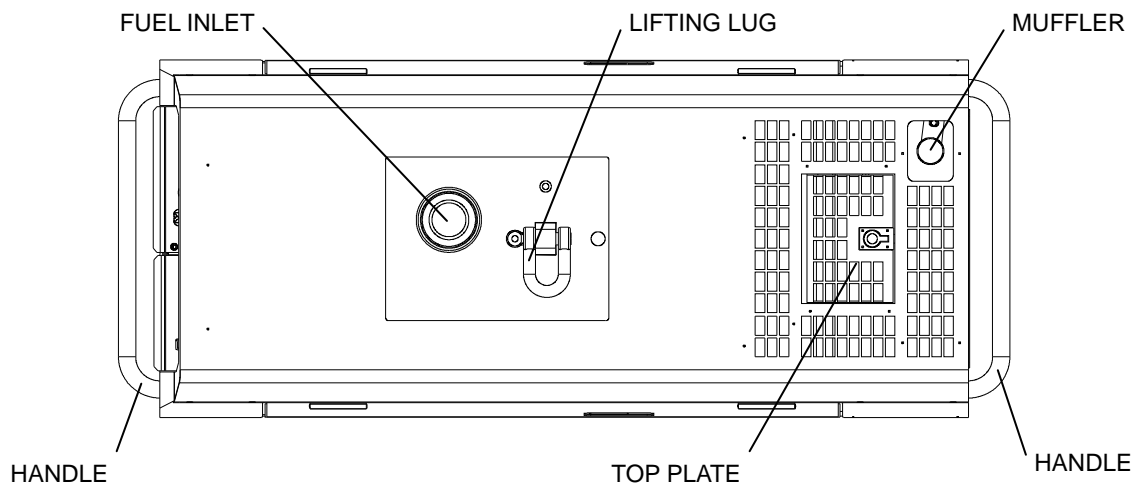
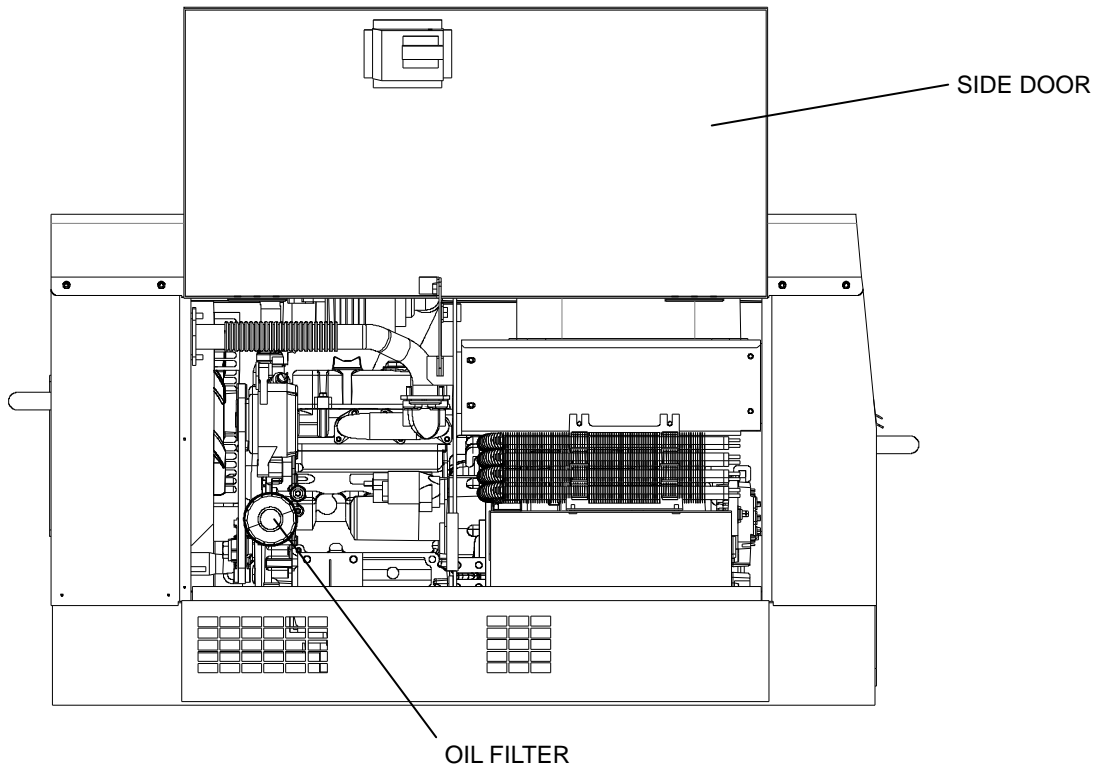

ACCESSORIES

| | | |
|--|-----------------------------|-------------------------|
| <p>OWNER'S AND OPERATOR'S MANUAL</p> | <p>ENGINE KEY 1PAIR</p> | <p>GROUNDING ROD x1</p> |
| <p>TOOL KIT</p> | <p>M6 BOLT x1</p> | |

5. Equipment

5-1. Eco Welding

The equipment is incorporated in Eco Welding feature that are aimed at performing the lower noise, the lower fuel consumption and the lower gas emission than conventional models.

When you turn the output selector switch to [ECO], you will be able to weld with Max 4.0mm welding rod at the low speed.

< Caution >

- When welding is performed, do not turn the output selector switch, which causes the burnout of the switch.
- [ECO] is designed for welding only. When AC output power is used by mistake, the breaker activates to TRIP.

5-2. Display

The equipment incorporates in digital display. It displays [AC VOLTAGE], [HOUR], [SPEED] successively, by changing the display selector switch.

< Caution >

- During operation, AC voltage meter always displays the 3-Phase voltage, apart from the circuit breaker position to [ON] or [OFF].

5-3. Monitor Lamp

The equipment is incorporated in monitoring function of [WATER TEMP], [CHARGE], [OIL PRESS].

Under normal condition, when the starter switch changes from [STOP] to [RUN], all the lamps of [CHARGE], [OIL PRESS] will be turned on.

When the engine starts, all the lamps will be turned off.

When abnormality is detected, the corresponding monitor lamp will flash, and the engine is automatically shutoff.

When the automatic shutoff is engaged, turn the starter switch to [STOP] position once, and then restart the engine. In the event the automatic shutoff is engaged next time, check which lamp turns on or off and investigate where is the abnormality.

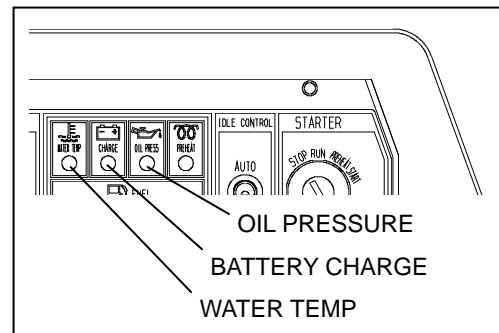

(1) Coolant/Water Temperature Monitor Lamp

⚠ Danger : Injuries

- Close all doors and place locks during operating this equipment, to avoid injuries by unintentional contact with cooling fan and fan belt.

⚠ Caution : Burns

- Do not open the radiator cap while operating this equipment or immediately after stopping the equipment, to avoid sustaining burns from hot vapor.
- Do not touch the engine and muffler during operation and immediately after stopping the equipment, for the temperature can reach extremely high.

When the water temperature rises abnormally, the coolant/water temperature monitor lamp will be flashing, and the automatic shutoff will be engaged. When this occurs, check the coolant/water reservoir tank, and replenish if needed. (Refer to [6-2. Checking Coolant/Water])
If the water level is normal, there may be a possibility of overloading. Always use the equipment within the rated output.

(2) Battery Charge Monitor Lamp

When the battery turns unable to be charged during operation, the battery charge monitor lamp will be flashed and the automatic shut-off will be engaged. In the event this occurs, consult with authorized distributor.

< Caution >

- The battery charge monitor cannot detect the degradation of the battery nor the battery fluid level. Check the battery fluid level periodically. (Refer to [6-5. Checking Battery])

(3) Oil Pressure Monitor Lamp

⚠ Danger : Injuries

- Close all doors and place locks during operating this equipment, to avoid injuries by unintentional contact with cooling fan and fan belt.

⚠ Caution : Burns

- Do not touch the engine and muffler during operation and immediately after stopping the equipment, for the temperature could reach extremely high temperature.
- When checking engine oil, always stop the engine, and wait until the engine cools down. If you open either the oil gauge or the oil filter cap during operation, hot oil may spilled out.

When the engine oil pressure drops during operation, the oil pressure monitor lamp will flash, and the automatic shutoff will be engaged. When this symptom occurs, check the engine oil level, and replenish to the maximum level if needed.

< Caution >

- The engine oil pressure monitor cannot detect the deterioration of engine oil itself. Check the engine oil periodically, and change if needed. (Refer to [11. Inspection and Maintenance])
- Check the fuse next, when the abnormality, other than [WATER TEMP], [CHARGE] or [OIL PRESS] is detected.
If the fuse is burned out, consult with authorized distributor, as there may be an abnormality of electrical components or wiring which would be inspected.

5-4. Remote Control(Optional)

The equipment incorporates with remote control receptacle feature. Remote control boxes are the optional parts. Remote control operation is available by connecting the compatible remote controller to the receptacle.

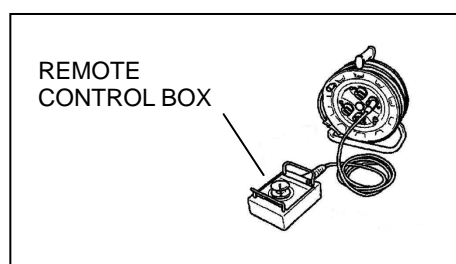

Adjust the welding current at the remote area from the machine.
 Attach the remote control receptacle, removing the receptacle cover.
 (M4 Screw 2 pieces)

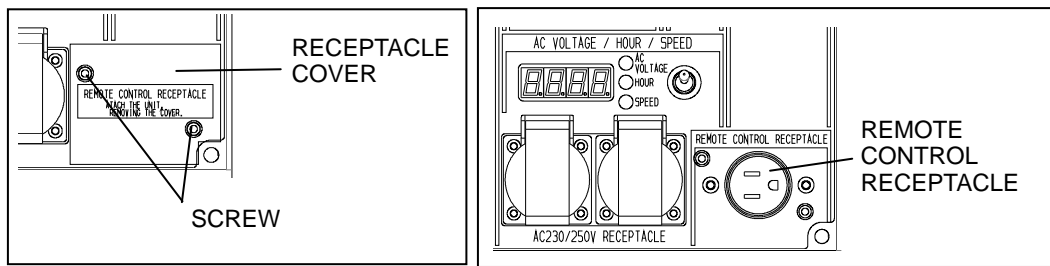

< Caution >

- When the remote control box is connected, the current adjustment dial of the equipment's front panel will not work.
- When the plug of remote control box has disconnected while welding, the current adjustment dial of the equipment will work. It may affect to increase or decrease the current accidentally.
- Never connect the plug of the remote control box / to the receptacle of the extension cable reel when the reel is connected to AC output receptacle.
- Never connect the other loads additionally than the remote control box.
- In the case the extension cable reel is installing the breaker, use the equipment to have turned the breaker [ON].

5-5. Earth Leakage Relay and Grounding

⚠ Danger : Electric Shock

- Ground every grounding terminal to the earth as set out in the manual. If even one of all is disconnected by mistake or accident, it will be much more dangerous for human injury or burns than the NO RELAY case, because leaking current inevitably goes through the body.
- Even though all the terminals of the loads have been grounded to the earth, the bonnet (canopy) grounding terminal should be grounded to the earth.
- Grounding should be made after the engine is stopped.
- Whenever the earth leakage relay has activated, you should always repair the leaking place first of all.

< Caution >

- The earth leakage relay activates only for AC output.
- The earth leakage relay activates when AC output is used with the output selector switch at [ECO] position for protection load damage.

The equipment is provided with the earth leakage relay in the Circuit Breaker to detect any leakage arisen due to the troubles as insulation failure of the load while the generator is running. And cutting off the circuit for protection against any accident such as electrical shock resulting from the trouble.

The specifications of the earth leakage relay:

- Rated Sensitive Current: 30mA (or below)
 (Grounding resistance: 500Ω or below)
- Sensitive time: Within 0.1 second

(1) Grounding Work

The qualified electrician should perform the grounding work of the following 2 points (500 Ω or below).

- The Outer Bonnet of the equipment (Earth grounding terminal and Bonnet grounding terminal)
- The Outer Bonnet of the load

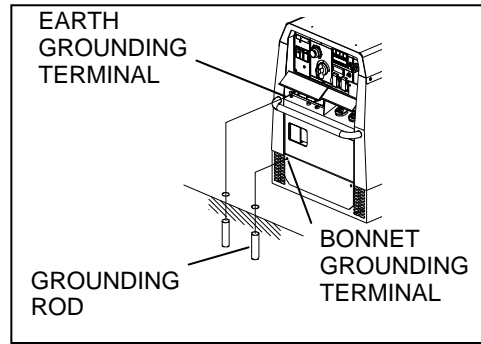

< Caution >

- In the event you cannot ground the generator to the earth, consult with the authorized distributor.

(2) Operation Check

Before operating the equipment, check always if the device can work duly as shown in the following procedure.

- ① Turn the starter switch to [RUN].
- ② Turn (Push-up) the circuit breaker (lever) to [ON] position.
- ③ Push the test button. The device is operating normally if the earth leakage indicator light turns on and the circuit breaker (lever) move to the tripped position (between [ON] and [OFF]).
- ④ Push the reset button. (the earth leakage indicator light turn off)
- ⑤ Reset the circuit breaker by pushing it down to the [OFF] position.
- ⑥ Restore the starter switch to [STOP].

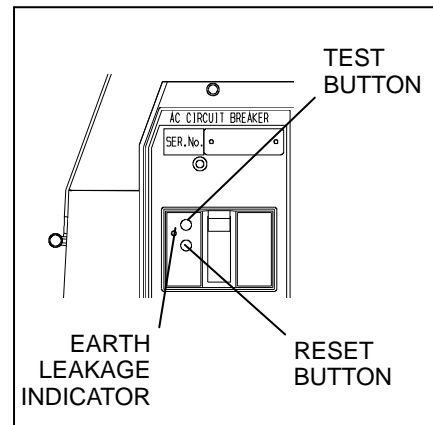

In the event you cannot complete all steps in the above procedure to the end, the device is out of order. Consult with the authorized distributor to repair.

(3) The Earth Leakage Relay has activated

⚠ Caution : Electric Shock / Injuries

- Be sure to disconnect all the loads to the equipment when turning the breakers ON again, after the earth leakage relay has activated.

When the earth leakage relay has activated, the circuit breaker (lever) move to the tripped position (between [ON] and [OFF]).

In the case, stop the engine promptly and find the leakage point to repair.

After repairing leakage point(s), proceed with the following restoration steps.

- ① Push the reset button or stop the engine.
 - ② Restore (Push - down) the circuit breaker (lever) to [OFF] position.
- By the above procedures. You can reset the breaker to [ON] position.

< Caution >

- When the breaker has tripped to the middle but the lamp does not turn ON simultaneously, the cause to have tripped is OVER-LOAD or AC output is used with the output selector switch at [ECO] position.

5-6. Auto Idle Feature

The Auto Idle feature is to set the engine speed low automatically (in about 8 seconds) for the purpose of reducing noise and fuel consumption, whenever no welding operation or electric supply is performed.

In the case of using the Auto Idle feature, turn the Idle Control Switch to [AUTO]. By the condition, the engine automatically moves to high speed, whenever welding operation or electric supply starts.

⚠ Caution : Damage to the equipment or other properties

- Turn always the Idle Control Switch to [HIGH], when the load is incorporated with any magnet switch.

< Caution >

- When the load of less than 0.5A is connected to use, the Auto Idle feature does not function sometimes. Therefore, turn the switch to [HIGH].
- When welding operation or electric supply performs alternately or intermittently, turn the switch to [HIGH].
- When the output selector switch is positioned to [ECO], the engine does not turn to high speed.

5-7. AC Voltage Adjustment Dial

⚡ Danger : Injuries · Electric Shock

- AC voltage adjust should be done, only after stopping the engine. Moreover, close doors and place locks during operating this equipment, to avoid injuries and electric shock.

⚠ Caution : Burns

- Do not touch the engine during operation and immediately after stopping the equipment, for the temperature can reach extremely high.

Adjust the dial whenever the AC output voltage adjustment is necessary.

< Caution >

- When raising the voltage, the current is decreasing. (Use the output within the output capacity.)
- In you raise the voltage exceeding the allowable voltage range, which causes the damage to the loads.

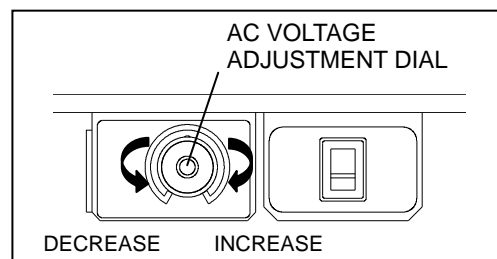

5-8. Frequency Change

⚡ Danger : Injuries

- Frequency change should be done, only after stopping the engine. Moreover, close doors and place locks during operating this equipment, to avoid injuries and electric shock.

⚠ Caution : Burns

- Do not touch the engine during operation and immediately after stopping the equipment, for the temperature can reach extremely high.

The equipment can be used to 50Hz and 60Hz.

Select the frequency according to the load by the frequency change switch located inside of the front door.

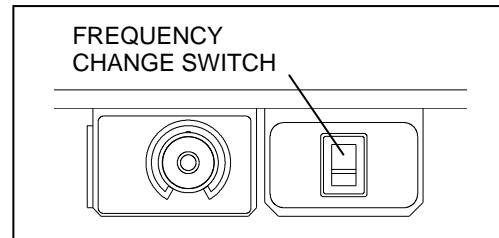

6. Initialization and Pre-operation check

⚠ Caution : Fire • Burns • Injuries

- When checking engine, always stop the engine, and keep away from fire. Wait until the engine cools down, before performing any inspection.

6-1. Checking Engine Oil

When checking for engine oil, be sure to keep the equipment leveled, and insert the oil gauge firmly.

Prior to starting the equipment, make sure to fill the engine oil to the UPPER line through the oil inlet.

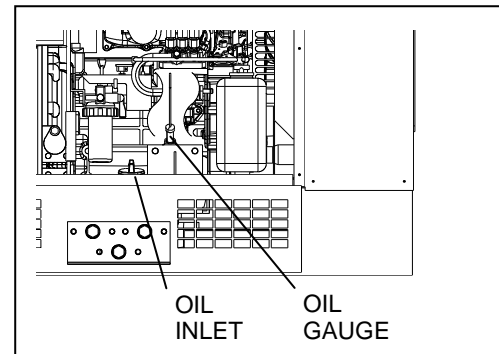

< Caution >

- If the equipment is not leveled, you cannot obtain accurate oil level. Do not overfill (over UPPER line) the engine oil. The excessive amount of engine oil may damage the engine (inside the cylinders)

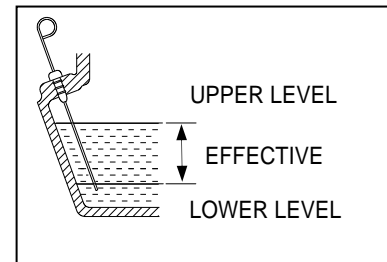

■ Selecting proper engine oil

< Caution >

- Use the API class CD or higher.

| | | | |
|-------------|------------|-------------|-------------|
| Temperature | Over +20°C | +10°C~+20°C | -10°C~+40°C |
| Viscosity | SAE30 | SAE20 | SAE10W/30 |

6-2. Checking Coolant / Water

⚠ Danger : Injuries

- Close all doors and place locks during operating this equipment, to avoid injuries by unintentional contact with cooling fan and fan belt.

⚠ Caution : Burns

- Do not open the radiator cap while operating this equipment or immediately after stopping the equipment, to avoid sustaining burns from hot vapor.
- Do not touch the engine and muffler during operation and immediately after stopping the equipment, for the temperature could reach extremely high temperature.

Check to see if the coolant/water level is between [FULL] and [LOW] levels in the coolant sub tank. If the coolant/water is below the [LOW] level, fill the tank and the radiator accordingly.

(1) Filling to the Coolant Sub Tank

- ① Remove the coolant sub tank cap.
- ② Fill up the coolant sub tank to the [FULL] level.
- ③ Install the cap back.

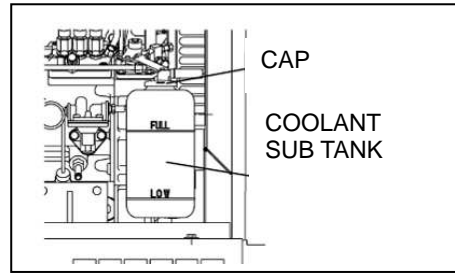

(2) Filling to the Radiator

- ① Open the top plate.
- ② Remove the radiator cap.
- ③ Fill the radiator up to the top.
- ④ Install the cap back and tighten.
- ⑤ Close the top plate.

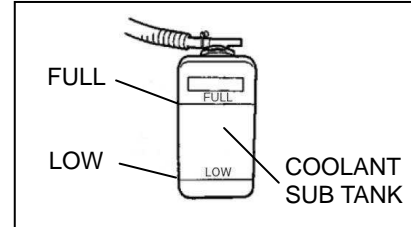

< Caution >

- Use Long Life Coolant (LLC), for prevent freeze and rust. (50% mixture LLC is filled when shipped from factory)
- Mixture ratio of the coolant should be 30%-50%, depending on the ambient temperature.
- Replace LLC at every 2year or 2000 hours.

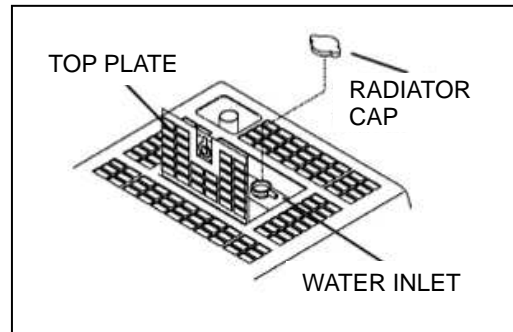

Mixture Ratio (for reference only)

| Lowest Ambient Temperature | -15°C | -23°C | -35°C |
|----------------------------|-------|-------|-------|
| Mixture Ratio | 30% | 40% | 50% |

6-3. Checking Fuel

⚠ Caution : Fire

- Always wipe any drip of fuel. Do not use this equipment when leakage is found. Repair the equipment before use.

Check for the fuel level in the tank. Add if necessary.
After adding fuel, retighten the tank cap securely.

< Caution >

- Use Diesel fuel, ASTM D975 No.2-D in the event ambient temperature reaches down to -5°C.
- Always use No.2-D diesel fuel. You are required not to use alternative fuel, because its quality is unknown or it may be inferior in quality.
- At temperatures less than -7°C(20°F), No.2-D fuel may pose operating problems. At colder temperatures, use No.1-D fuel (if available) or use a "winterized" No.2-D (a blend of No.1-D and No.2-D). This blended fuel is usually called No.2-D also, but can be used in colder temperatures than No.2-D fuel which has not been "winterized". Check with the services stations operator to be sure you can get the properly blended fuel.

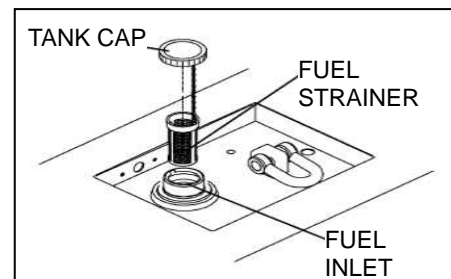

- Always use the fuel strainer.
- Fill the fuel tank slightly less than the full tank.
- Diesel fuel specification type and sulfur content %(ppm) used, must be compliant with all applicable emission regulations for the area in which the engine is operated.

6-4. Checking Fuel, Engine Oil and Water Leakage

⚠ Caution : Fire

- Do not use this equipment when leakage is found. Repair the equipment before use.

Be sure to check any leakage for fuel, oil and coolant/water at the hose connections by opening side doors. Whenever checking any fuel leakage, turn the fuel lever open and be sure to close the fuel lever after checking.

6-5. Checking Battery

⚠ Caution : Injuries to eyes and skin

- Battery fluid contains diluted sulfuric acid. Avoid contact with eyes, skin or clothing.
- If the acid comes to contact, especially with eyes, flush with a lot of water, and contact your physician immediately.

⚠ Caution : Explosion

- Do not use the equipment or charge the battery, in the case the battery fluid level is lower than the LOWER level.
- Battery may emit some combustible gas, so keep it away from fire and sparks.

- ① Check the fluid level. If the level is near or lower than LOWER level, add distilled water until the fluid level reaches UPPER level.
- ② Make sure that the battery cables are firmly secured to the posts. Tighten the clamps if necessary.

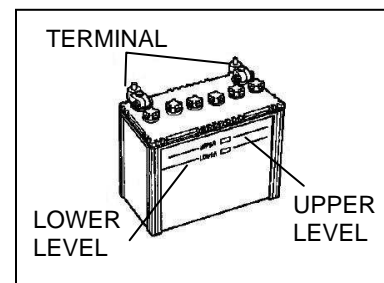

< Caution >

- Check the hydrometer of the battery fluid. If it falls below 1.23, the battery requires recharging. Please consult with authorized distributor.

■ Replacing battery

- ① Remove the under plate.
(M6 Bolt 2 pieces)
- ② Remove the clamp and cable from negative [-] post on the battery.
(Remove always negative side first)
- ③ Remove the hold-down clamp from the battery.
- ④ Remove the clamp and cable from positive [+] post on the battery.
- ⑤ Remove the battery from the seat.

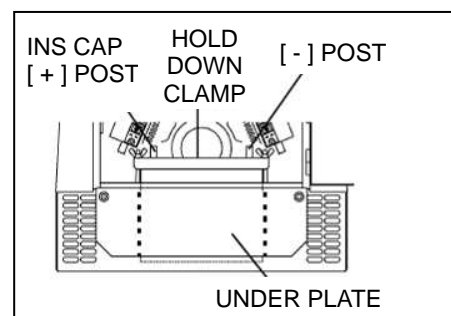

※Reinstall a new battery in the reverse order. (Install always the cable to the positive [+] post in the new battery first.)

< Caution >

- Use the following battery. <Japan Industrial Standard : 46B24L>
- When replacing a battery, remove the under plate firstly. Otherwise the battery slanted and the fluid may leak and contact to eye or skin.

7. Operating the Engine

⚠ Danger : Suffocation from exhaust fume

- Exhaust fume from the engine contains many elements harmful to human. Do not operate this equipment in poorly ventilated area, such as inside a room or in a tunnel.

⚠ Caution : Suffocation from exhaust fume

- Do not redirect the exhaust fume toward pedestrians or building.

⚠ Caution : Fire

- Temperature around muffler and exhaust can get extremely high. Keep any inflammable items (such as fuel, gas, paint, etc.) away from the equipment.
- Always operate this equipment on flat surface and, at least 1 meter away from any objects (wall, box, etc.)

⚠ Caution : Injuries

- Always place the equipment on a flat and stable surface, to keep the equipment from sliding.
- Before starting the engine, be sure to disconnect the loads and set the breaker to [OFF] position.

⚠ Caution : Burns

- Do not touch the engine and muffler during operation and immediately after stopping the equipment, for the temperature could reach extremely high temperature.

< Caution >

- Check to see if it is safe around the equipment before starting.
- When working is performed together by two or more persons, take care to perform all work safely.
- Do not use the location of dusty, hot and humid.
- Close all doors and place locks during operating this equipment, to damage the equipment by decrease of cooling performance.
- When the equipment is noisy, it use additional hearing protection item to prevent the abnormal auditory.

7-1. Starting

- ① Turn the breaker to [OFF].
- ② Turn the fuel lever to [OPEN].
- ③ Turn the idle control switch to [AUTO].
- ④ When the temperature is below -5°C, turn and keep the Starter switch to [PREHEAT] until the preheat lamp turns off (about 5 seconds).

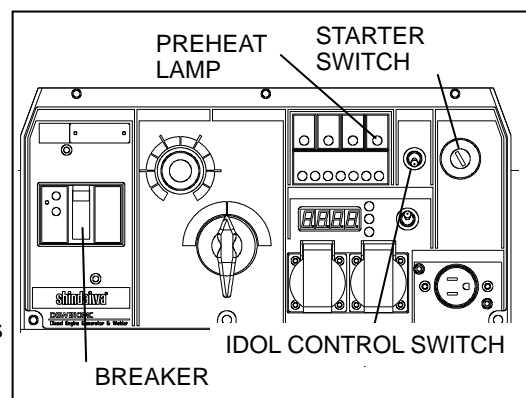

- ⑤ Turn the starter switch to [START] and then the engine starts by the starter motor.
- ⑥ Release the starter switch, as soon as the engine has started.
- ⑦ Keep the engine idle for about 5 minutes.

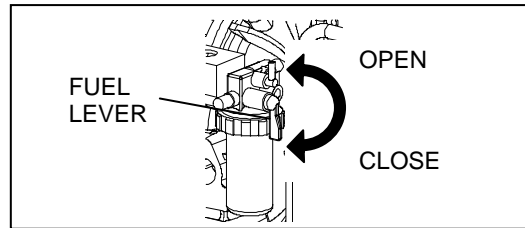

< Caution >

- Do not drive the starter motor for more than 15 seconds successively.
- If you need to restart, wait for 30 seconds or more before reattempt.
- Once the engine has started, never turn the starter switch to [START].

■ Restart after stopping due to fuel shortage

This equipment is incorporated in automatic vacuuming air feature. Therefore, even though the engine stops due to running out of fuel, you can restart the engine easily by the following steps.

- ① Turn the breaker to [OFF].
- ② Turn the Starter Switch to [STOP].
- ③ Fill the fuel.
- ④ Turn the idle control switch to [AUTO].
- ⑤ Turn the starter switch to [START] and drive the starter motor for about 10 seconds.
- ⑥ Release the starter switch, as soon as the engine has started.
- ⑦ Wait for about 1 minute to vacuum the air out. The engine speed becomes stable when the air is extracted.

< Caution >

- Never turn the engine high speed or connect the loads until the air is extracted completely (the engine speed becomes stable).

7-2. Stopping

- ① Turn the breaker to [OFF].
- ② Turn the idle control switch to [AUTO].
- ③ Keep the engine idle (cooling down) for about 5 minutes.
- ④ Turn the starter switch to [STOP].
- ⑤ After the engine has stopped, turn the every fuel lever to [CLOSE].

< Caution >

- When the engine does not stop in spite of turning the starter switch to [STOP], Turn the fuel lever to [CLOSE], then the engine will stop in a few minutes. In this case, be sure to consult with authorized distributor and ask to repair.
- Do not attempt to turn to [STOP] position while actual welding or utilizing AC power source, it may cause the serious damage on the unit.

8. Welding Operation

8-1. Selection – Welding Cable

Select the cable with proper gauge, based on the allowable amperage and the length, per the table shown below.

The welding capacity is to reduce if the small gauge cable is used.

< Caution >

- Welding cables should be used unstrained. When the welding cables are used in swirl, the welding capacity is to reduce.

Size of Cable (Unit : mm²)

| Return Length \ Welding Current | 20m | 30m | 40m | 60m | 80m | 100m |
|---------------------------------|-----|-----|-----|-----|-----|------|
| 300A | 30 | 38 | 50 | 80 | 100 | 125 |
| 250A | 22 | 30 | 38 | 60 | 80 | 100 |
| 200A | 22 | 30 | 30 | 50 | 60 | 80 |
| 150A | 22 | 22 | 22 | 38 | 50 | 60 |
| 100A | 22 | 22 | 22 | 30 | 30 | 38 |

8-2. Polarity

There are two welding output terminals, [+] and [-].

Select the polarity according to the operation, referring to the table below.

< Caution >

- Follow the instruction of the welding rods, the polarity of which is specified.
- If connected by different polarity and the same work is simultaneously used by two types of machine, the voltage between folders may receive an electric shock. That one operator has two folders absolutely should avoid.

| | Application | Connection |
|------------------|---|---|
| Normal Polarity | Generals Welding, such as Construction | Minus to holder (Rod) Plus to the Earth (Material) |
| Reverse Polarity | Thin Plate, Build-Up Welding Stainless Steel | Minus to the Earth (Material) Plus to holder (Rod) |

8-3. Connection – Welding Cable

⚠ Danger : Electric Shock

- Before connecting or disconnecting a welding cable from welding output terminals, stop the engine, and remove the engine key. A person performing should always keep the key.

- ① Stop the engine.
- ② Connect a welding cable to a crimping terminal, a welding rod holder and a material holder.
- ③ Connect a welding cable to a welding output terminal.
- ④ After connecting cables, be sure to close output terminal covers.

< Caution >

- Be sure to crimp a crimping terminal to a cable and connect the cable to welding output terminal. Otherwise, welding output terminals may burn out by the heat caused by insufficient connections.
- Do not use a cable without a crimping terminal. If you use the cable, the insulation is peeled off partly, to bind to an output terminal, the output terminal may burn out by the heat caused by insufficient connections and also a bare part of the cable may touch the bonnet to short-circuit.

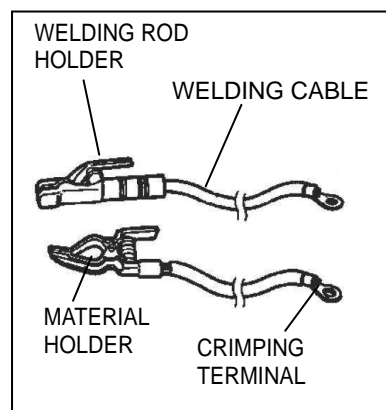

8-4. Welding

⚠ Danger : Electromagnetic Interference

- Person with a pacemaker of the heart, do not approach the equipment and welding around the work site during work. May adversely affect the operation of the pacemaker.

⚠ Caution : Suffocation from welding fume

- Be sure to wear a fume proof mask in operation, because welding fume contains poisonous gas and dust. Pay attention to the airflow direction and sufficient ventilation also in order to prevent from inhaling the fume.

⚠ Caution : Injuries to eyes and skin

- Be sure to wear spark protection glass(es)(Refer to the table below), long-sleeve shirts, gloves, etc. in order to protect eyes and skin from harmful spark in welding.

Standard for Spark Protection Glass (Japan Industrial Standard)

| No. | 7 | 8 | 9 | 10 | 11 | 12 | 13 |
|---------------------|-------|---|--------|----|----|---------|----|
| Welding Current (A) | 30-75 | | 76-200 | | | 201-400 | |

⚠ Caution : Fire

- Keep any inflammable items and easily burning items away from the place in welding, because welding splashes spatters.

⚠ Caution : Burns

- Be sure to wear leather gloves, apron, shoe covers, eye protection glass(es)(mask), safety shoes, safety cap and long sleeve shirts, because welding splashes spatters.

The output adjustable range by the current adjustment dial, depends on the position each of the output selector switch and frequency change switch. (Refer to [2. Specifications])

- ① Turn the idle control switch and frequency change switch, according to the operation.
- ② Set the current amperage by the current adjustment dial, per the table below.

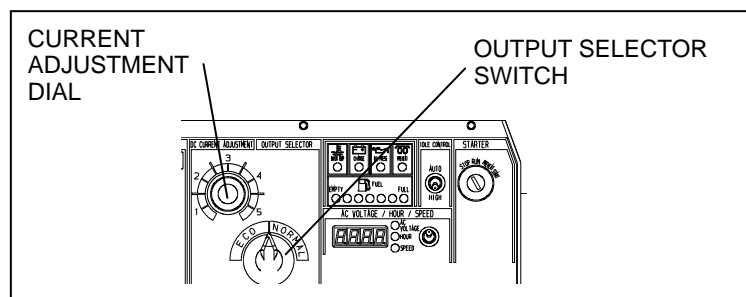

| Position | Freq | Welding Current at the dial position | | | | | | |
|----------|------|--------------------------------------|----|-----|-----|-----|-----|-----|
| | | MIN | 1 | 2 | 3 | 4 | 5 | MAX |
| ECO | | 30 | 45 | 70 | 95 | 120 | 145 | 160 |
| NORMAL | 50Hz | 35 | 60 | 110 | 160 | 205 | 255 | 280 |
| | 60Hz | 45 | 70 | 125 | 180 | 230 | 285 | 310 |

The values shown in the table are for reference only. The length and the ambient temperature affect the value.

When the remote control box is used, the values change to some degree.

9. Generator Operation

9-1. Output Range

(1) 3-Phase 400V/440V (3-Phase 4-Wire)

Maximum output by the 3-Phase output terminal is 9.9kVA.

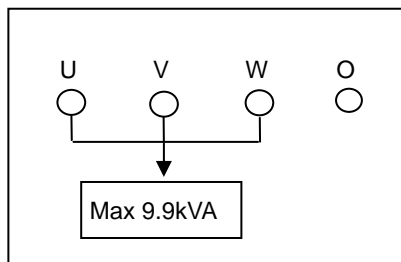

(2) 1-Phase 400V/440V

1-Phase 400V/440V output is available through 1 pair out of 3 terminals.

Maximum output by the 1 pair of 3 terminals is 6.0/6.6kVA(50Hz/60Hz).

Maximum output by the 3 pair of 3 terminals is total 8.0kVA.

You should connect the load for 3 pairs evenly as possible to terminals.

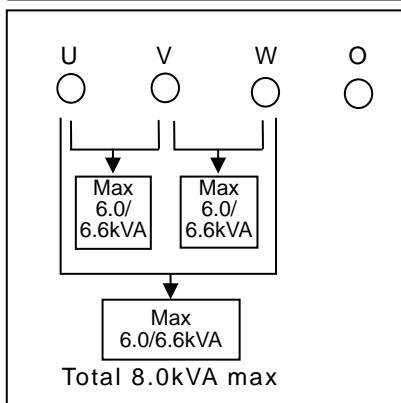

(3) 1-Phase 230V/250V

1-Phase 230V/250V Output is available through 2 receptacle sets.

Maximum output by 1 receptacle set is 3.45/3.75kVA(50Hz/60Hz).

Maximum output by 2 receptacle set is 6.9/7.5kVA(50Hz/60Hz).

9-2. Output Limitation

Please refer to the following table, because electric tools and home appliances cannot be judged only by the rated output or the power consumption due to the efficiency and character of the components.

Applicable Load (For reference purpose only)

| Loads | Capacity (Unit : kW) | | | | |
|---|--------------------------|------------------------|------------------------|-----------------------|-------------------|
| | 1-Phase 230V/250V | | 1-Phase 400V/440V | | 3-Phase 400V/440V |
| | Receptacle 1 set | Receptacle 2 sets use | 1 pair of 3 terminals | 3 pair of 3 terminals | Terminal |
| Electric Bulb, Heater, etc. | 3.45(50Hz) 3.75(60Hz) | 6.9(50Hz) 7.5(60Hz) | 6.0(50Hz) 6.6(60Hz) | 8.0 | — |
| Electric Tools(Series Motor), etc | 1.7(50Hz) 1.8(60Hz) | 3.4(50Hz) 3.7(60Hz) | 3.0(50Hz) 3.3(60Hz) | 4.0 | — |
| Mercury Bulb (High Power Factor Type) | 1.3(50Hz) 1.5(60Hz) | 2.7(50Hz) 3.0(60Hz) | 2.4(50Hz) 2.6(60Hz) | 3.2 | — |
| Submersible Pump, Compressor, etc (Induction Motor) | 1.3(50Hz) 1.5(60Hz) | 2.7(50Hz) 3.0(60Hz) | 2.4(50Hz) 2.6(60Hz) | 3.2 | 4.0 |

※ Series Motor : Motor with brush

※ Induction Motor : Brushless Motor

※ The value described is [OUTPUT] for Induction Motor loads and [POWER CONSUMPTION] for the other equipment.

< Caution >

- Be sure to confirm the frequency designated in the equipment incorporated in mercury bulb or induction motor.
- The load incorporated in motor may require bigger power than the rated power consumption. Therefore, consult with authorized distributor to clarify.
- When connecting to use 2 or more sets, start the load one by one, not to start them simultaneously.
- When switching a Mercury bulb ON again, wait for approximately 15 minutes until the bulb cools down.

9-3. Operation

⚠ Danger : Electric Shock

- Before connecting or disconnecting a plug from output receptacle or terminal, always turn the earth leakage circuit breaker to OFF position.
- Ground the every grounding terminal to the earth as set out in the manual. If even one of all is unconnected by mistake or accident, it will be much more dangerous for human than the NO-RELAY case, because leaking current inevitably goes through the body.
- Even though all the current leakage relays in the loads have been grounded to the earth, the earth grounding terminal and the bonnet (canopy) should be grounded to the earth.
- Grounding should be made after the engine is stopped.
- Whenever the current leakage breaker activates, you should repair the leaking place first of all.

⚠ Caution : Injuries

- Be sure to connect to output terminals or insert a plug to a receptacle, after confirming that all the switches in the loads are positioned to [OFF].
- Be sure to select the correct frequency, designated in the loads.

⚠ Caution : Damage to the property - Aftermath

- Whenever connecting to use medical equipment or appliances, be sure to consult with the medical equipment company, doctor or hospital personnel.
- Be sure to select the correct frequency, designated in the loads. Otherwise the loads may be damaged.

< Caution >

- During operation, AC voltage meter always displays the voltage in 400/440V AC output both at the breaker position [ON] and [OFF].

- ① Select the correct frequency, designated in the loads.
(Refer to [5-8. Frequency Change])
- ② Turn the power switch to [OFF] in the load.
- ③ Start the engine. (Refer to [7-1. Starting])
- ④ Turn the breaker to [OFF].
- ⑤ Connect the load to the output receptacles or terminal.

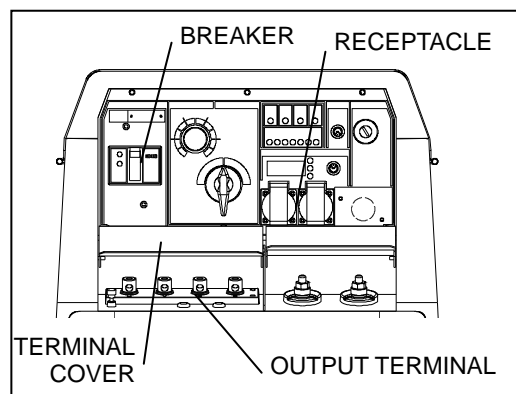

- ⑥ After connecting cables, be sure to close output terminal covers and fit it with the bolt.
- ⑦ Turn the breaker to [ON].

■ The Circuit breaker has activated due to overload

⚠ Caution: Injuries

- Be sure to turn the power switch off in the load when turning the circuit breaker to [ON] again, when the circuit breaker has activated.

When the electric supply exceeds the rated output (overload), the circuit breaker activates to trip off in order to shut down the circuit. When the load operation stops during operation, check the circuit breaker.

When breaker has tripped, restore the circuit breaker as per the following procedure.

- ① Turn off all the power switches in the loads.
- ② Turn up the breaker to [ON].

< Caution >

- Take care for overload, referring to [9-2. Output Limitation].

10. Simultaneous Use of Welding and Generating

The circuit breakers react on the AC power supply circuit only. In the simultaneous use of welding and generating, there sometimes happens overload to the engine. Refer to the following table and limit the AC power use.

Limitation of AC power supply
in the simultaneous use of welding and generating (Instance of 60Hz)

| Welding Output | AC Power Output | |
|------------------------|------------------------------|----------------|
| Welding Rod / Amperage | 3-Phase Output (P.F. 0.8) | 1-Phase Output |
| φ 2.0mm / 60A | 9.3kVA | 7.4kVA |
| φ 2.6mm / 120A | 7.2kVA | 5.7kVA |
| φ 3.2mm / 140A | 6.4kVA | 5.1kVA |
| φ 4.0mm / 160A | 5.7kVA | 4.5kVA |
| φ 5.0mm / 240A | 2.0kVA | 1.6kVA |
| φ 6.0mm / 300A | 0kVA | 0kVA |

※ The 1-P figure shown is the total output of 1-P 230/250V and 1-P 400/440V.

< Caution >

- The simultaneous use of Eco welding and AC power is NOT available.
- Avoid the simultaneous use in the case high quality result in welding is required.

11. Inspection and Maintenance

Danger : Electric Shock • Injuries

- Before performing any equipment check or maintenance, stop the engine, and remove engine key. A person performing the maintenance should always keep the key.
- Close all doors and place locks during operating this equipment, to avoid injuries by unintentional contact with cooling fan and fan belt.

Caution: Fire • Burns

- Keep the equipment far away from fire.
- Wait until the engine cools down, before performing any inspection. Because some parts/components (flexible tube, etc.) could reach very high temperature inside the equipment.

Caution: Burns

- Do not open the radiator cap while operating this equipment or immediately after stopping the equipment, to avoid sustaining burns from hot vapor.

Caution : Injuries to eyes and skin

- Battery fluid contains diluted sulfuric acid. Avoid contact with eyes, skin or clothing.
- If the acid comes to contact, especially with eyes, flush with a lot of water, and contact your physician immediately.

Caution : Explosion

- Do not use the equipment or charge the battery, in the case the battery fluid level is lower than the LOWER level.
- Battery may emit some combustible gas, so keep it away from fire and sparks.

To optimize the use of this generator/welder, we recommend the periodical equipment checks and maintenance based on the following matrix.
Use the hour meter as a guide for the operating time.

< Caution >

- The authorized technicians should perform all checking and maintenance work, except for the pre-startup checks.
- Request for the maintenance item with ● mark to authorized distributor.
- Always use our genuine parts of replacement.
- When draining waste fluid from the equipment, catch it by tray.
- When disposing of oil, fuel, coolant (LLC), fuel filter, battery and /or other harmful disposal, please observe the relevant environmental protection regulations.
- Please do not dispose the harmful items or waste fluid to the ground to a river, pond, and ocean to keep our environment clean and neat.
- Check to see if it is safe around the equipment before open the door.
- Close all doors and place locks, if you leave from the equipment for a while.

| Checking Items | | Startup Check | Checking Time | | | | | |
|----------------|--|---------------|----------------------|----------------------------------|----------------------------------|---------------|----------------|----------------|
| | | | At 50hrs | Every 100 hrs | Every 200 hrs | Every 400 hrs | Every 1000 hrs | Every 2000 hrs |
| 1 | Check and Supply Fuel | ○ | | | | | | |
| 2 | Check and Supply Engine Oil | ○ | | | | | | |
| 3 | Engine Oil Change | | 1 st ○ | 2 nd or after ○ | | | | |
| 4 | Oil Filter Change | | 1 st ○ | | 2 nd or after ○ | | | |
| 5 | Check/Add Water/Coolant | ○ | | | | | | |
| 6 | Water/Coolant Change | | | | | | | ○ or 1year |
| 7 | Clean Fuel Strainer | | 1 st ○ | 2 nd or after ○ | | | | |
| 8 | Change Fuel Filter | | | | | ○ | | |
| 9 | Drain Water/Clean Fuel Tank | | | | ○ | | | |
| 10 | Check Leakage Fuel, Oil, Water | ○ | | | | | | |
| 11 | Check/Add Battery Water | ○ | | | | | | |
| 12 | Clean Air Element | | 1 st ○ | 2 nd or after ○ | | | | |
| 13 | Change Air Element | | | | | ○ | | |
| 14 | Adjust V-Belt Tension | | 1 st ● | 2 nd or after ● | | | | |
| 15 | Change V-Belt | | | | | ● or 2year | | |
| 16 | Clean Radiator Fin | | | | | ● | | |
| 17 | Clean Radiator (inside) | | | | | ● | | |
| 18 | Change Fuel Hose, Oil Hose, Vibration-Absorbing Rubber | | | | | | | ● or 2year |
| 19 | Adjust Engine Valve Clearance | | | | | | ● Adjust | ● Plane |

| Checking Items | Startup Check | Checking Time | | | | | |
|----------------|-------------------------------|---------------|---------------|---------------|---------------|----------------|----------------|
| | | At 50hrs | Every 100 hrs | Every 200 hrs | Every 400 hrs | Every 1000 hrs | Every 2000 hrs |
| 20 | Check/Adjust Injection Nozzle | | | | ● | | |
| 21 | Check/Adjust Injection Pump | | | | | | ● |

(1) Oil Change

| | |
|--------------------------|-----------------|
| First Time | 50 hour mark |
| 2 nd or after | Every 100 hours |

- ① Remove the oil plug.
- ② Loosen the oil drain plug and allow the oil to drain fully.
- ③ Reinstall the oil drain plug.
- ④ Checking the oil level by the oil level gauge, add oil into the oil filler to fill up to the max level (Approx. 3.8L).
- ⑤ Reinstall the oil plug hand tight.

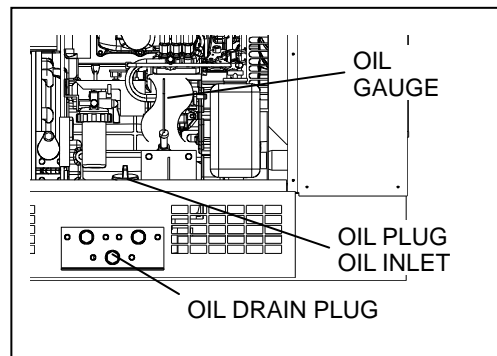

< Caution >

- Refer to [6-1. Checking Engine Oil] to select engine oil.
- Change the packing, whenever changing oil.
- Packing No. : 6C090-58961 (Kubota)
- After reinstalling the oil drain plug tightly, keep the engine drive for a while to check no engine oil leakage and then stop the engine.

(2) Oil Filter Change

| | |
|--------------------------|-----------------|
| First Time | 50 hour mark |
| 2 nd or after | Every 200 hours |

- ① Drain the engine oil completely, as described in [11 (1) Oil Change].
- ② Loosen and remove the oil filter, using an oil filter wrench.
- ③ Smear a little engine oil on the rubber gasket of a new filter.
- ④ Screw the new filter into place and tighten it by hand until the gasket contact the seat. Then, give it additional [1.1/4 Turn] to seat the filter, using an oil filter wrench.
- ⑤ Supply oil and install the filler cap.

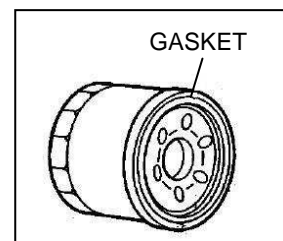
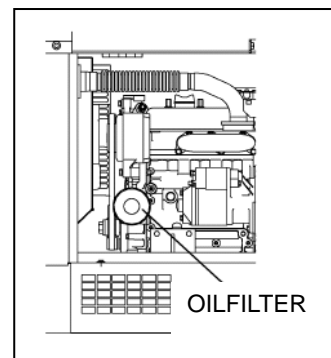

< Caution >

- If an oil filter wrench is not available, contact with authorized distributor.
- Oil Filter Part No. : 15241-32090 (Kubota)
- After the engine oil supply, keep the engine drive for a while to check no engine oil leakage and then stop the engine.

(3) Clean/Change Air Filter Element

| | |
|--------|---|
| Clean | 1 st 50 hours and Every 100 hours afterwards |
| Change | Every 400 hours |

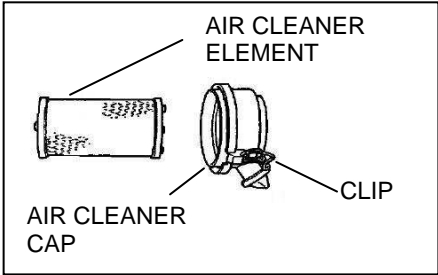
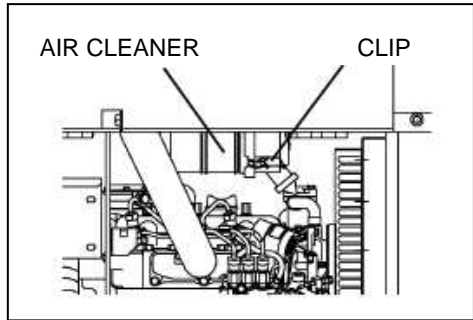

- ① Disconnect the air cleaner cap by releasing the clips.
- ② Remove the air element.
- ③ Clean or change the air element.
 - <The element is adhered with dried contaminants>
Blow up compressed air from inside the element.
 - <The element is adhered with carbon or oil>
Replace to a new one.
- ④ Reinstall them in reverse order.

< Caution >

- Clean more frequently, if it is used in dusty environment.
- Element Part No. : 1G659-11221 (Kubota)

(4) Clean/Change Fuel Strainer

| | |
|--------|---|
| Clean | 1 st 50 hours and Every 100 hours afterwards |
| Change | Every 400 hours |

- ① Turn the fuel lever to [CLOSE].
- ② Unscrew the retainer ring counterclockwise, and remove the cup and the filter element.
- ③ Discard any dust or water inside the cup, and clean the filter element by blowing compressed air, or change if necessary.
- ④ Reassemble it back.

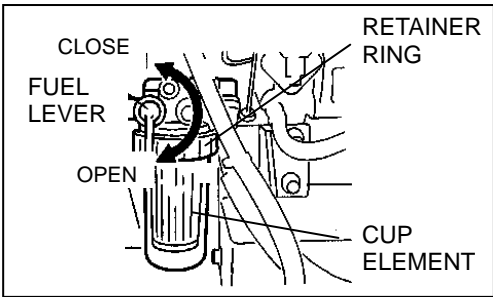

< Caution >

- Be sure to check for any contaminants on the packing, whenever reinstalling the cup.
- Turn the fuel lever to [OPEN] after assembling, and check for any leak. Having confirmed no leak without fail, turn the fuel lever to [CLOSE].
- Element Part No. : 16271-43561 (Kubota)

(5) Drain Water from Fuel Tank

| | |
|-------------|-----------------|
| Drain Water | Every 200 hours |
|-------------|-----------------|

- ① Unscrew the fuel drain plug.
- ② Reinstall the drain plug, after draining water completely.

< Caution >

- Change the packing, whenever drain water.
- Packing Part No. : 6C090-58961 (Kubota)
- After reinstalling the fuel drain plug tightly, check no fuel leakage.

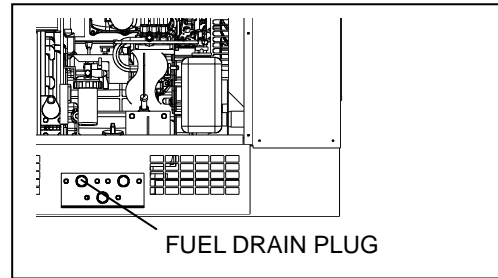

(6) Changing Coolant/Water

| | |
|--------|-----------------------------|
| Change | Every 2000 hours or 2 years |
|--------|-----------------------------|

(Total coolant/water capacity: about 3 L, including sub tank capacity 0.6 L)

- ① Open the top plate.
- ② Remove the radiator cap.
- ③ Loosen the water drain plug.
- ④ After draining all the water, reinstall the water drain plug.

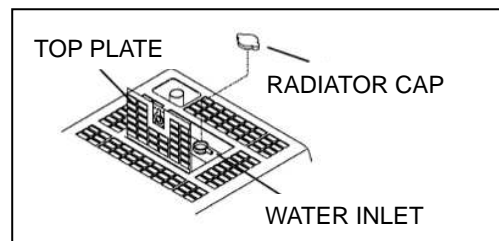

< Caution >

- Change the packing, whenever changing coolant/water.
 - Packing Part No. : 6C090-58961 (Kubota)
- ⑤ Replace all the water in the sub tank.
 - ⑥ Fill the radiator coolant/water up to the MAX level (to the upper edge of the inlet).
 - ⑦ Reinstall the radiator cap.
 - ⑧ Close the top plate.

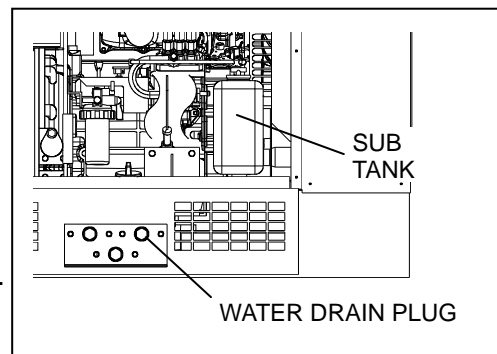

< Caution >

- After reinstalling the water drain plug tightly, keep the engine drive for a while to check no water leakage and then stop the engine.

12. Long-Term Storage

⚠ Danger : Electric Shock

- Before performing any equipment check or maintenance, stop the engine, and remove the engine key. A person performing the maintenance should always keep the key.

⚠ Caution : Injuries

- Before performing any equipment check or maintenance, stop the engine, and remove the engine key. A person performing the maintenance should always keep the key.

⚠ Caution : Fire • Burns

- When checking engine, always stop the engine, and keep far away from fire. Temperature around muffler and exhaust can get extremely high. Wait until the engine cools down, before performing any inspection.

If the equipment will not be used for more than two months, perform the following maintenance and storage procedures.

- ① Remove the battery.
- ② Change the engine oil.
- ③ Drain fuel from the fuel tank, the fuel strainer.
- ④ Remove the engine key and save it.
- ⑤ Clean all parts, cover the generator/welder, and keep it in the storage, away from dust and humidity.

< Caution >

- Recharge the removed battery once a month.

13. Troubleshooting

⚠ Danger : Electric Shock

- Do not operate the equipment, if the equipment or you are wet.
- Before performing any equipment check or maintenance, stop the engine.

⚠ Caution : Injuries

- When performing equipment check and maintenance, always stop the engine.

⚠ Caution : Fire • Burns

- When checking engine, always stop the engine, and keep far away from fire. Temperature around muffler and exhaust can get extremely high. Wait until the engine cools down, before performing any inspection.

Follow the guideline below, when performing any troubleshooting.

If you cannot resolve the problems by this troubleshooting guide, contact with authorized distributor to request the repair.

| Symptoms | Possible cause | Corrective actions |
|---------------------------------------|---|--|
| Starter motor does not start | <ol style="list-style-type: none">1. Weak battery2. Dead battery | <ol style="list-style-type: none">1. Recharge battery2. Replace battery |
| Engine does not start | <ol style="list-style-type: none">1. Fuel lever on fuel strainer to [CLOSE]2. Insufficient fuel3. Fuel is contaminated by the water or dust4. Fuse burnt | <ol style="list-style-type: none">1. Open the fuel lever for fuel strainer2. Replenish fuel3. Drain water or clean fuel tank, fuel strainer4. Repair the fuse |
| Engine starts, but stalls immediately | <ol style="list-style-type: none">1. Insufficient oil2. High water temperature3. Unable to charge | <ol style="list-style-type: none">1. Replenish oil2. Operate the machine within the rated output3. Repair |

| Symptoms | Possible cause | Corrective actions |
|---|---|---|
| Excessive black smoke exhaust from muffler | 1. Overloaded use | 1. Operate the machine within the rated output |
| Engine does not stop | 1. Stop solenoid malfunction | 1. Turn the fuel lever to [CLOSE] to stop and repair |
| Welding arc is weak | <ol style="list-style-type: none"> 1. Output selector switch at [ECO] 2. Frequency switch at [50Hz] 3. Wrong current adjustment dial position 4. Improper connection of cables 5. Improper Cable Diameter 6. Improper connection to the base material 7. Simultaneous use of welding and Generating 8. Welding output short circuit | <ol style="list-style-type: none"> 1. Change to [NORMAL] 2. Change to [60Hz] 3. Turn the dial clockwise 4. Connect securely 5. Replace the cables based on the [Welding Cable Selection] 6. Connect securely 7. Stop using AC power output 8. Resolving short circuit |
| Excessive welding arc | 1. Wrong current adjustment dial Position | 1. Turn the dial Counterclockwise |
| No AC output | <ol style="list-style-type: none"> 1. The breaker position to [OFF] 2. Output selector switch at [ECO] | <ol style="list-style-type: none"> 1. Turn to [ON] 2. Change to [NORMAL] |
| AC output is weak | <ol style="list-style-type: none"> 1. Wrong frequency 2. The rated current of the load exceeds the rated output 3. Simultaneous use of welding and Generating | <ol style="list-style-type: none"> 1. Change to load frequency 2. Adjust according to [OUTPUT LIMITATION] 3. Stop welding |
| Unable to activate the Idle control feature | <ol style="list-style-type: none"> 1. Idol control switch is to [HIGH] 2. The power consumption of the load is 1A or below 3. Welding output short circuit | <ol style="list-style-type: none"> 1. Turn to [AUTO] 2. Set the idol control to [HIGH] 3. Resolving short circuit |
| Unable to adjust the welding current by remote controller | <ol style="list-style-type: none"> 1. Connected AC load to remote control receptacle 2. The switch(breaker) on the cord reel at OFF | <ol style="list-style-type: none"> 1. Disconnect AC load 2. Turn to ON |

14. Engine Wiring Diagram

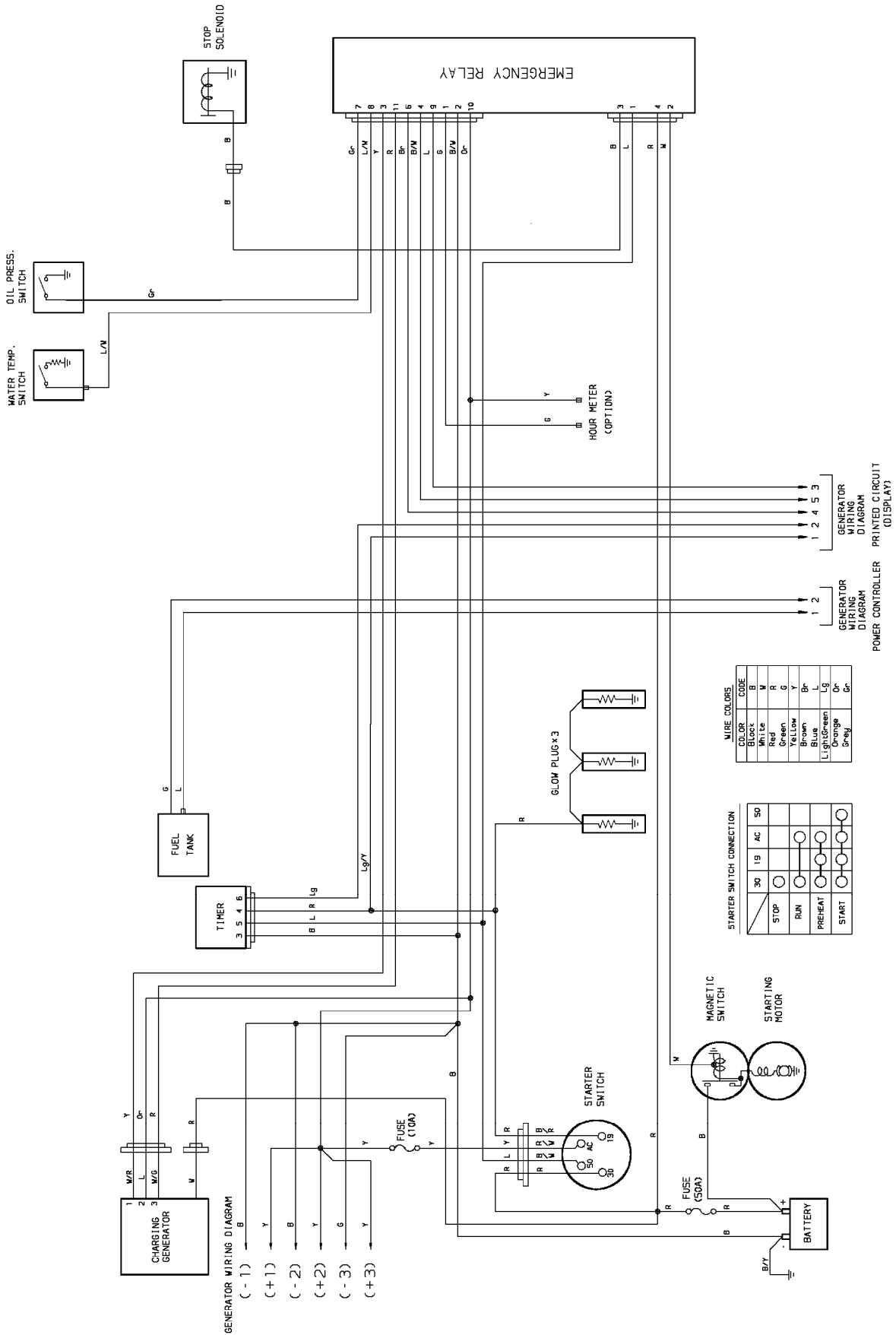

15. Generator Wiring Diagram

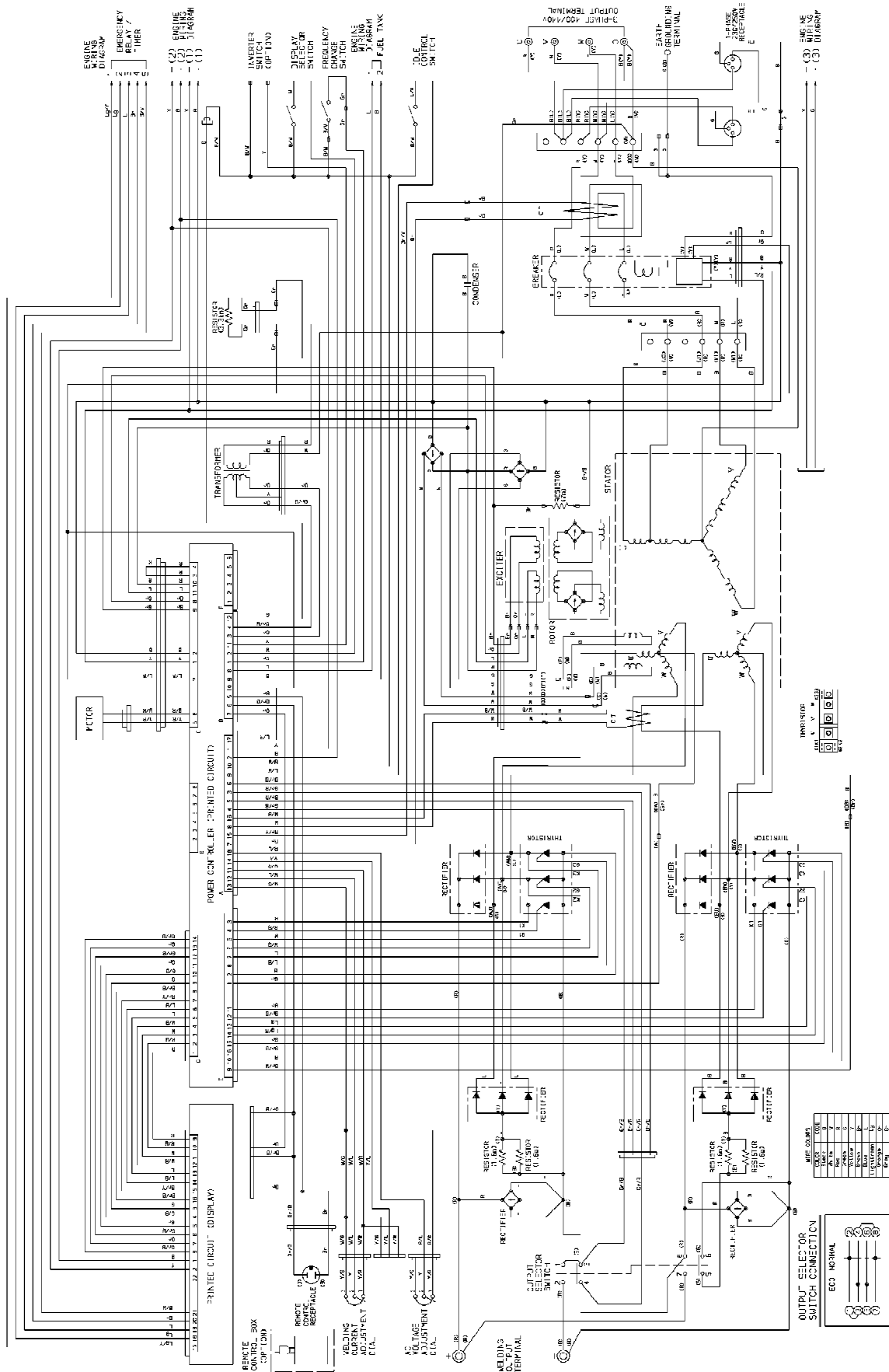

YAMABIKO CORPORATION
7-2 SUEHIROCHO 1-CHOME, OHME, TOKYO 198-8760, JAPAN
PHONE: 81-428-32-6118. FAX: 81-428-32-6145.

shindaiwa[®]