

shindaiwa®

OWNER'S AND OPERATOR'S MANUAL

Diesel Engine Generator & Welder

DGW500DM

Vertical, Water-Cooled 4-Cycle Diesel Engine

 **CAUTION**

Do not operate the Generator/Welder, or any other appliance, before you have read and understood the instructions for use and keep near for ready use.

DGW500DM-200
X750-023 04 0
X750803-680 2

Introduction

We would like to thank you very much for purchasing this Shindaiwa Soundproof Diesel Engine Generator & Welder.

- This manual has been created in order to ensure safe and proper use of this equipment. Be sure to thoroughly read this manual before operating the equipment as the improper operation of this equipment can result in an accident or malfunction.
- This equipment should only be operated by persons who thoroughly understand the contents of this manual and can safely operate the equipment. Persons who are ill, taking medicine, or are in bad health should not operate this equipment if such conditions will affect operation of the equipment and related work.
- Operation and use of this equipment must be in strict compliance with the applicable laws, as well as rules and regulations based on such laws.
- Always be sure to include this manual with the equipment if it is loaned out to another party, and instruct said party that they must thoroughly read this manual before operating the equipment.
- Store this manual securely in a predetermined location so that it can be readily accessed at all times to order parts or arrange for repair. Contact the retail outlet where this equipment was purchased if any parts are lost, the equipment becomes soiled, or is otherwise damaged in any manner.
- Consult with the retail outlet where the equipment was purchased if any of the points are unclear or you would like further information.
Be sure to note the model name and serial number of your equipment, and provide this information when making an inquiry.
- If disposing of this equipment, dispose in a manner according to laws and regulations applicable to industrial waste. Consult with the retail outlet where the equipment was purchased if you have any inquiries regarding proper disposal.

■ The precautions used in this manual are divided into the following three ranks.

⚠ Warning : Improper operation can result in death or serious personal injury.

⚠ Caution : Improper operation can result in moderate or minor personal injury, or physical damage.

<Note> : Explanatory note in order to ensure that equipment protection and performance are fully realized.

- It is possible that items described under **< ⚠ Caution >** or **<Note>** can result in a serious accident depending on the circumstances. The contents of both of these types of precautions are important. Be sure to always comply with all precautions.

Table of Contents

1. Safety Precautions	2
2. Specifications	6
3. Applications	6
4. Part Names	7
5. Equipment	9
5-1. VRD (Voltage Reduction Device)	9
5-2. Idle Control	9
5-3. Weld Output Control	10
5-4. Remote Control (Option)	10
5-5. Meter.....	11
5-6. Error Code Display	12
5-7. Monitor Lamp.....	12
5-8. Frequency Selector	13
5-9. Ground Fault Circuit Interrupter (GFCI) and Grounding.....	14
5-10. Emergency Stop Switch	15
6. Pre-Operation Inspection	15
6-1. Engine Oil Inspection.....	16
6-2. Cooling Water Inspection	16
6-3. Fuel Inspection	17
6-4. Inspection for Fuel/Oil/Cooling Water Leakage.....	18
6-5. Battery Inspection.....	18
7. Operating Procedures	19
7-1. Starting the Engine	20
7-2. Stopping the Engine	21
7-3. Emergency Stop	21
8. Using as a Welder	21
8-1. Welding Cable Selection	21
8-2. Welding Polarity.....	22
8-3. Welding Cable Connection	23
8-4. Duty Cycle	24
8-5. Welding Work	24
9. Using as a Generator	26
9-1. Output Types and Ranges.....	26
9-2. Usable Device Capacities.....	27
9-3. Operation	28
10. Simultaneously Welding and Using as AC Power Source	29
11. Inspection/Maintenance	30
12. Long-Term Storage	35
13. Troubleshooting	36
14. Engine Wiring Diagram	39
15. Generator Wiring Diagram	40

1. Safety Precautions

⚠ Warning: Suffocation from Exhaust Fume

- Do not operate the equipment in a poorly-ventilated area such as indoors or within a tunnel because the engine exhaust fume includes components that are harmful to humans.

⚠ Warning: Suffocation from Welding Fume

- Always be sure to wear a fume-proof mask when welding as the fumes generated during welding include harmful gases and dust. Also be careful that the wind direction is not such that it will cause fumes to be inhaled and always operate the equipment in a well-ventilated area.

⚠ Warning: Electric Shock

- Do not operate the equipment with any doors or covers open.
- Do not touch wirings or any electric parts inside the equipment during operation.
- Do not touch the equipment during operation if the equipment or your body is wet.
- Be sure to stop the engine whenever touching Weld output terminals such as when installing or removing welding cables.
- Do not connect welding cables to any part other than Weld output terminals.
- Do not insert any metallic objects, such as pins or wires, into AC output receptacles or remote controller connectors.
- Always be sure to turn off all breakers before installing or removing devices using AC output receptacles and AC output terminals.
- Always be sure to repair the corresponding ground fault location when ground fault circuit interrupters operate.
- Always be sure to stop the engine and remove the starter key before performing any equipment check or maintenance.

⚠ Warning: Fire

- Always be sure to stop the engine when inspecting fuel or refueling, and absolutely never perform such tasks near fire or other open flame. Wait until the engine has completely cooled before inspecting fuel or refueling.
- Always be sure to wipe up any spilled fuel or oil.
- Absolutely never use the equipment if there is a fuel, oil or cooling water leak, and be sure to always repair the leak before using.
- Absolutely never inspect or perform maintenance to the equipment near fire or other open flame.
- Keep any ignitable items (such as fuel, gas and paint) or inflammable items away from the equipment because the muffler, exhaust fume and other parts attain high temperatures.
- Keep any ignitable items (such as fuel, gas and paint) or inflammable items away from the work area due to the scattering of weld spatter that occurs during welding.
- Provide at least 1 meter (3 feet) of distance between the equipment and walls and other obstacles, and operate the equipment on a flat surface.
- Allow the equipment to cool before covering with protective covers and similar items.
- Do not ground wiring of ground fault circuit interrupters of the equipment to piping that passes through flammable material.

⚠ Warning: Injury

- Do not operate the equipment with any doors or covers open. There is a danger of hair, body parts and other items being caught up in moving parts such as cooling fans and belts.
- Do not modify the equipment and do not operate with parts removed.
- Always be sure to stop the engine and remove the starter key before performing any equipment check or maintenance.

⚠ Warning: Injury to Eyes and Skin

- Use protective gear, such as rubber gloves, when inspecting or replacing the battery due to the dilute sulfuric acid in the battery fluid. Be sure that fluid does not get into eyes, or on skin or clothing.
- If battery fluid gets into the eyes, or on the skin or clothing, immediately wash with a large amount of water, and always be especially sure to seek medical attention if it gets into the eyes.

⚠ Warning: Explosion

- Do not operate the equipment or recharge the battery when the battery fluid level is below the lower level.
- Do not generate any sparks near the battery and do not allow any fire or other open flame near the equipment because the battery generates ignitable gas.

⚠ Warning: Electromagnetic Interference

- Persons using a heart pacemaker are not allowed near the welder or welding work area while welding is being performed without the permission of a doctor. The welder generates a magnetic field while energized that can negatively affect pacemaker operation.

⚠ Caution: Suffocation from Exhaust Fume

- Do not direct the engine exhaust towards passersby, private homes or similar persons/locations because the engine exhaust fume includes components that are harmful to humans.

⚠ Caution: Electric Shock

- Do not sprinkle water on the equipment and do not use where exposed to rain.
- If wearing gloves, be sure to always wear gloves with dry insulation properties. Do not wear gloves that are damaged or wet.

⚠ Caution: Burn

- The engine, muffler and similar parts are extremely hot during operation and immediately after stopping the equipment. Never touch hot parts.
- Never open the radiator cap during operation or immediately after stopping the equipment. Hot cooling water and steam will spurt out.
- Always be sure to stop the engine and allow it to cool before inspecting or changing the engine oil. Opening the oil gauge or oil plug during operation will result in hot oil spurting out.

⚠ Caution: Injury

- Use this equipment with it situated on a stable level surface so that it is prevented from moving.
- Do not move the equipment during operation.
- Always be sure to turn off the switches of all devices using the equipment and turn off the equipment breakers before starting the engine.
- Always be sure to turn off the power switches of all devices using the equipment when turning on the equipment breakers. Leaving on the power switch of a device using the equipment when the equipment breakers are turned on could result in the sudden operation of the corresponding device.
- Do not leave on the power switch of a device using the equipment and do not connect a device to an AC output receptacles and an AC output terminals.
- The lifting lug is designed to be used only for lifting the equipment. Do not lift the equipment with any heavy items (such as a trailer, gas canister and additional fuel tank) added to the equipment.
- Always be sure to use the lifting lug when lifting the equipment, and lift slowly and directly straight above.
- Wear a helmet, safety shoes, gloves and similar protective gear when performing lifting work. Do not stand or get under the equipment while it is suspended.
- Securely fix the equipment with rope or similar item so that it cannot move when transporting by truck or other vehicle.

⚠ Caution: Injury to Eyes and Skin

- Always be sure to wear arc-proof glasses, clothes that completely cover the skin and other protective gear when welding to protect the eyes and skin from harmful light rays generated during welding.
- Always be sure to wear leather gloves, apron, shoe covers, arc-proof glasses (face shield), safety shoes, hard hat and long-sleeve clothing to protect against the scattering of weld spatter that occurs during welding.

⚠ Caution: Physical and Secondary Damage

- Do not use the equipment for any improper applications. Improper usage can result in an accident or malfunction.
- Do not connect the AC power source to indoor wiring.
- If using the equipment as a power source for medical equipment, you must check with the medical equipment manufacturer, doctor and hospital before using the equipment.
- Set the frequency in accordance with the devices using the equipment.

■ Locations of Warning Labels

Replace warning labels when they become difficult to see or damaged by affixing new labels in the specified locations. Order the necessary labels by numbers in parentheses.

- (1) Suffocation from Exhaust Fume (No. X505-007590)
- (2) Suffocation from Welding Fume (No. X505-007600)
- (3) Electric Shock (No. X505-007610)
- (4) Fire (No. X505-007650)
- (5) Injury (No. X505-007630)
- (6) Injury (No. X505-007690)
- (7) Injury (No. X505-007550)
- (8) Burn (No. X505-007640)
- (9) Burn (No. X505-007620)
- (10) Burns (No. X505-007660)
- (11) Electric Shock (No. X505-007680)

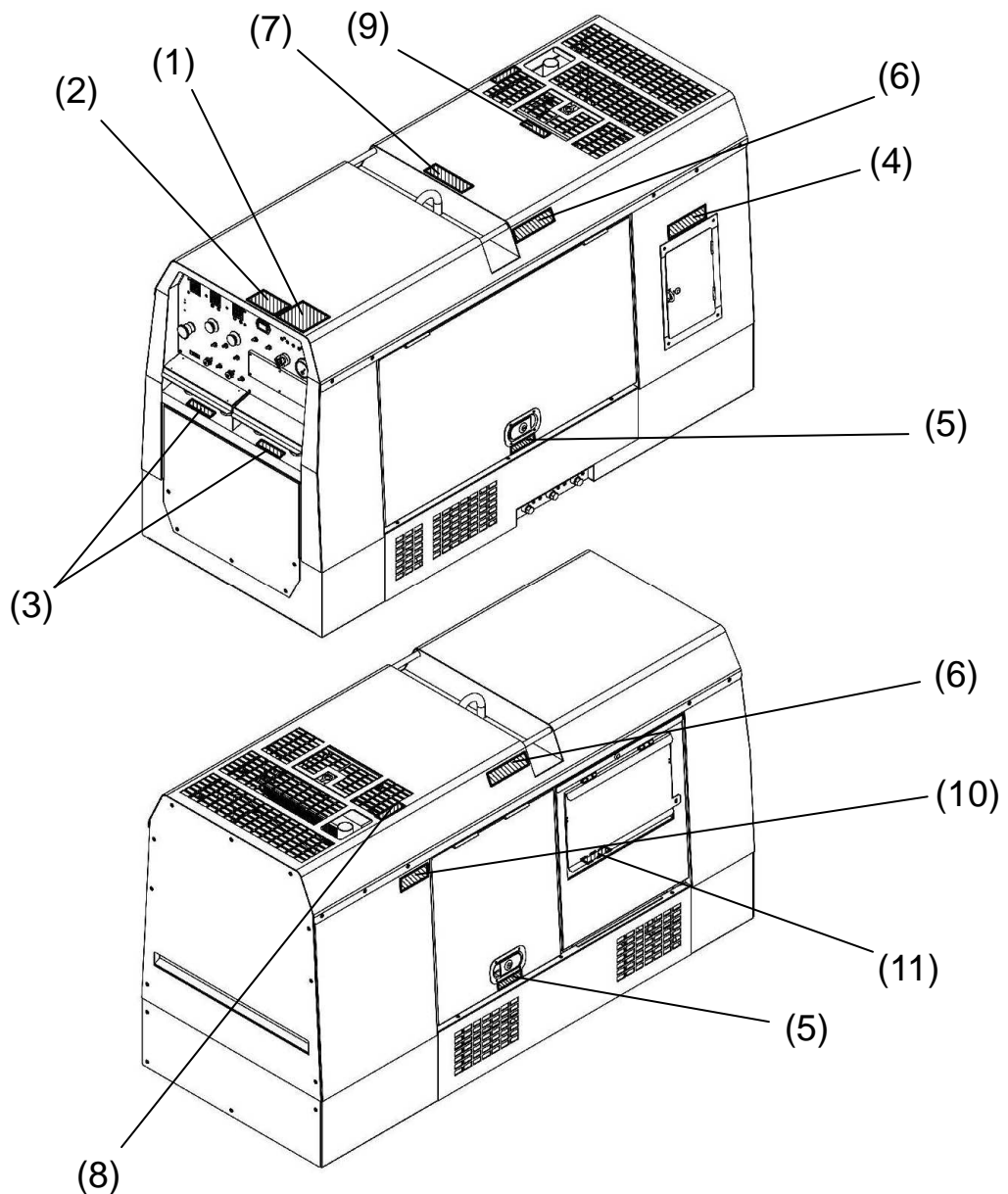

2. Specifications

Model		DGW500DM-200		
Generating Method		Rotating Field		
Welding DC Generator	Operation		Single	Dual
	CC	Rated Current (A)	480	230
		Rated Voltage (V)	39.2	29.2
		Duty Cycle (%)	60	80
		Current Adj. Range (A)	60 – 500 / 65 – 500	30 – 280 / 35 – 280
		Welding Rod (mm)	φ 2.6 – φ 8.0	φ 2.0 – φ 6.0
		Gouging Rod (mm)	φ 3.2 – φ 9.5	φ 3.2 – φ 5.0
	CV	Rated Current (A)	480	230
		Rated Voltage (V)	39.0	22.5
		Duty Cycle (%)	60	80
		Voltage Adj. Range (V)	14 – 40	14 – 29
Welding Wire (mm)		φ 0.6 – φ 2.4	φ 0.6 – φ 2.0	
Rated Speed (min ⁻¹)		3000 / 3600		
No Load Voltage (V)		MAX 85		
AC Generator	Rated Frequency (Hz)		50 / 60	
	Rated Speed (min ⁻¹)		3000 / 3600	
	Phase		1-Phase	3-Phase
	Rated Voltage (V)		115 / 127	200 / 220
	Rated Current (A)		20Ax2	28.6 / 26.0
	Power Factor		1.0	0.8
	Rated Output (kVA)		4.6 / 5.1	9.9
	Rating		Continuous	
Engine	Model		Kubota V1505	
	Type		Vertical, Water-Cooled 4-Cycle Diesel Engine	
	Displacement (L)		1.498	
	Rated Output (kW/min ⁻¹)		24.5 / 3000	27.0 / 3600
	Fuel		ASTM No.2-D Diesel Fuel or Equivalent	
	Lubricant Oil		API Class CD or better	
	Lubrication Oil Volume (L)		6.0 (Effective 2.0)	
	Cooling Water Volume (L)		5.6 (Sub Tank Capacity 0.8 L included)	
	Starting Method		Starter Motor	
Battery		75D31R(Japanese Industrial Standard)		
Fuel Tank Capacity (L)		63		
Dimension	Length (mm)	1680		
	Width (mm)	700		
	Height (mm)	950		
Dry Weight (kg)		614		

3. Applications

- Shielded Metal Arc Welding
- Semi-automatic Arc Welding (MIG, MAG, Self-Shielded)
- Scratch Start TIG
- Gouging
- Power Source for Light, Electric Tools and Appliances

⚠ Caution: Physical and Secondary Damage

- Do not use the equipment for any applications not listed above. Improper usage can result in an accident or malfunction.
- If using the equipment as a power source for medical equipment, you must check with the medical equipment manufacturer, doctor and hospital before using the equipment.

4. Part Names

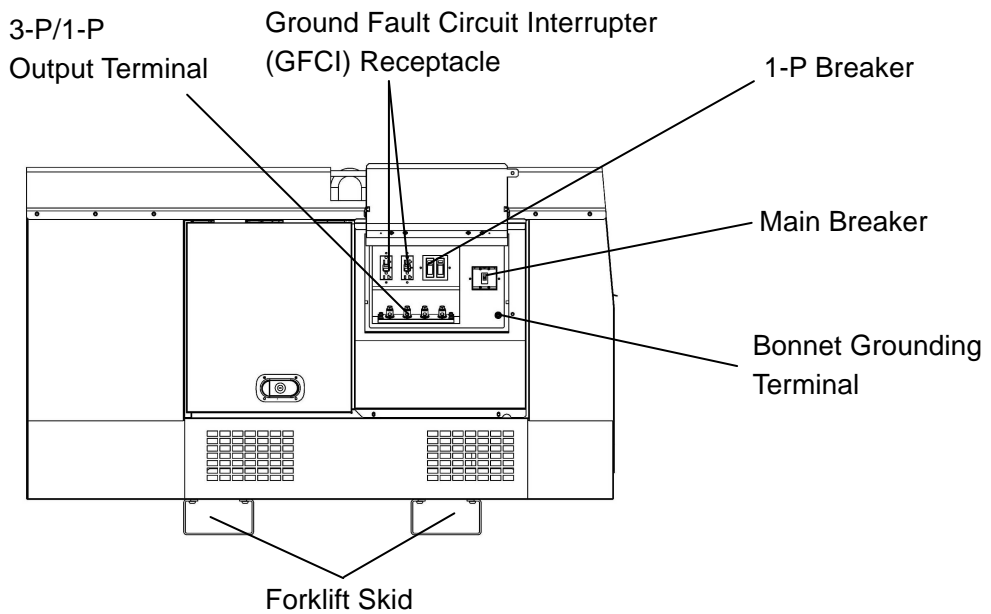
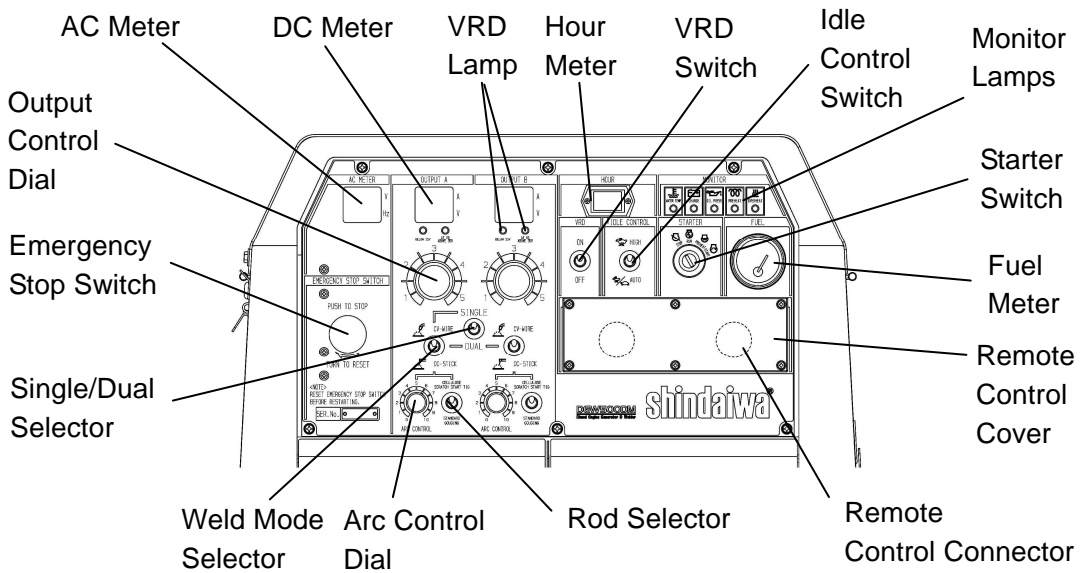
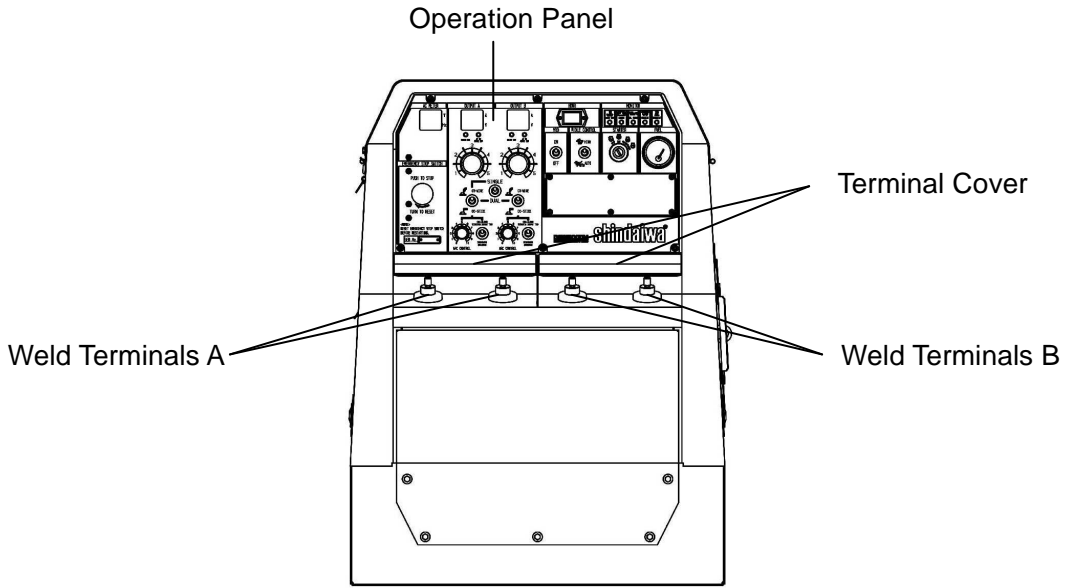

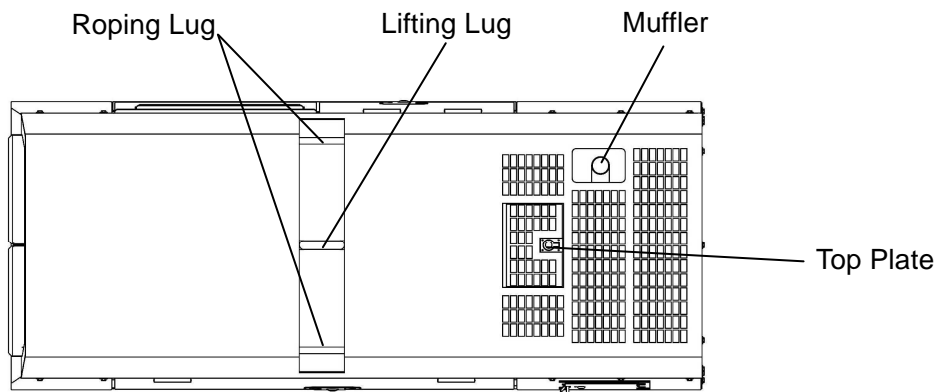
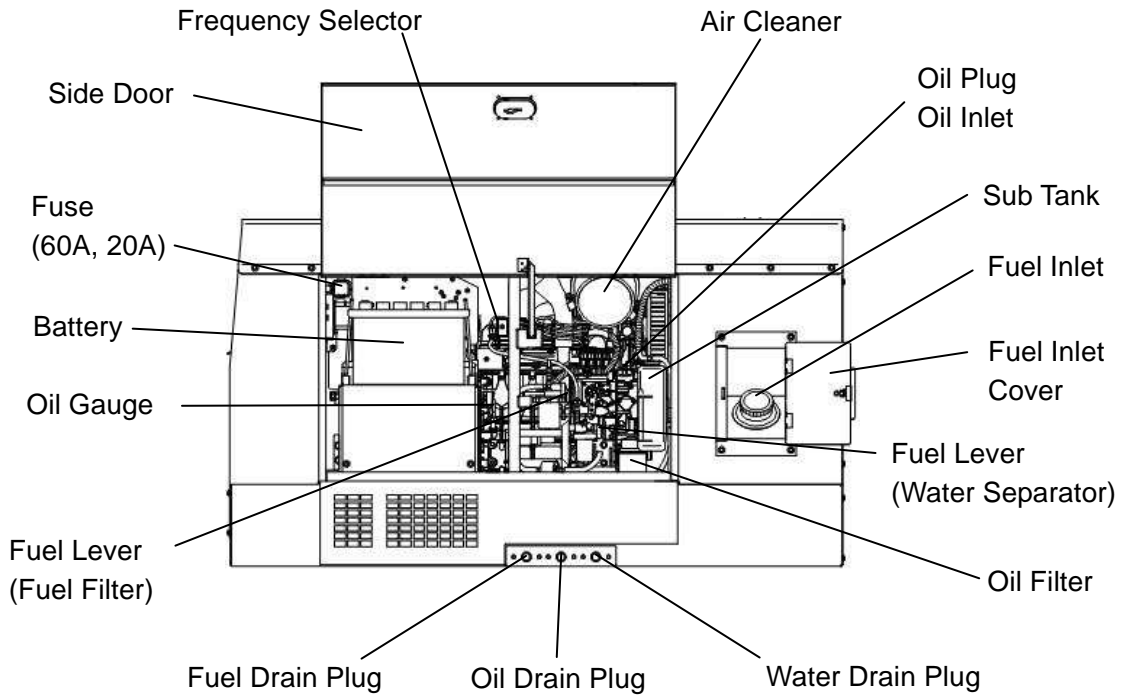

Accessories

Owner's and Operator's Manual

Starter Key 1 Set

Door Key 2 Set

Tool Kit

M6 Bolt 1 part

5. Equipment

5-1. VRD (Voltage Reduction Device)

The equipment includes a voltage reduction device on the weld output side. The voltage reduction device reduces the output voltage of the welder when welding is paused in order to further increase safety when welding in locations with high humidity, elevated locations, extremely confined spaces near possible hazards, and similar conditions.

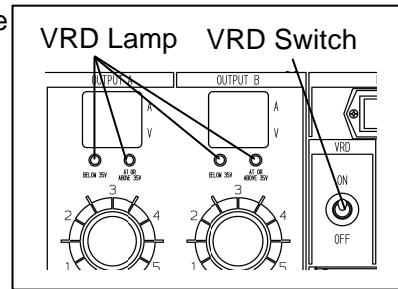

When the VRD switch is set to "ON" and not welding, the voltage reduction device reduces the voltage of the Weld output terminals to 35 V or less.

When welding is started, the voltage-reduction function is cancelled and the equipment returns to the reduced voltage status when welding is completed.

Turning the VRD switch to "OFF" also cancels the voltage-reduction function.

The green VRD lamp ("BELOW 35V" side) lights up when weld output voltage is less than 35 V and the red lamp ("AT OR ABOVE 35V" side) lights up when the voltage is 35 V or more.

<Note>

- The VRD is only for weld output. It does not function for AC generated output voltage.

5-2. Idle Control

The equipment includes an idle control function. You can use the idle control switch to select an engine speed setting of "AUTO", "HIGH".

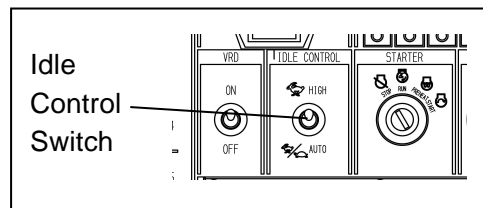

(1) Auto Idle

The equipment includes an auto idle function in order to reduce noise, save fuel, and reduce exhaust gas emission.

You can set the idle control switch to "AUTO" so that the engine operates at low speed when not welding or using the equipment as a power source.

When you start to weld or use as an AC power source, the engine automatically increases to high speed. When in a no-load condition, the engine automatically returns to low speed after approximately eight seconds of high-speed operation.

<Note>

- Set the idle control switch to "HIGH" if using a high capacity motor, precision instruments or AC load with an attached magnetic switch.
- Set the idle control switch to "HIGH" if using as an AC power source of a device of 0.5 A or less because the engine might not reach a high speed as speed control does not operate at that level.

(2) High Idle

You can set the idle control switch to "HIGH" to maintain the engine constantly at high speed.

5-3. Weld Output Control

(1) Weld Mode Selector

You can select a weld mode of "CV-WIRE" or "CC-STICK" in accordance with the type of welding being performed.

- CV (Constant Voltage) -WIRE
You can use the equipment as a power source for semi-automatic arc welding (MIG, MAG and self-shielded).
- CC (Constant Current) -STICK

Welding can be performed at a constant uniform current even if the arc length changes due to a shaky hand or similar cause to provide a stable arc that is not easily extinguished.

Welding can be performed at a specified current value without being affected by the length or thickness (thinness) of the welding cable.

This mode is optimal for general welding as the stable arc reduces the amount of spatter.

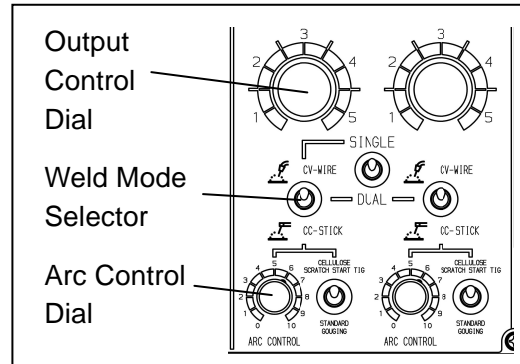

(2) Weld Output Pre-Set

The equipment includes a weld output pre-set function.

If the weld mode selector is set to "CV-WIRE", you can pre-set the output voltage using the output control dial.

If the weld mode selector is set to "CC-STICK", you can pre-set the output current using the output control dial.

(3) Arc Control (for CC-STICK mode)

The equipment includes an arc control function that adjusts the arc strength.

You can adjust the setting of the arc control dial of the short-circuit current of the weld output.

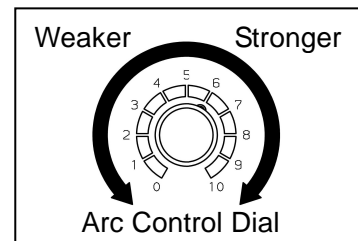

<Note>

- The arc control function is only for "CC-STICK" mode. It does not function if using "CV-WIRE".
- Always turn the arc control dial to "0"(zero) when the scratch start TIG welding is functioned otherwise a welding current becomes unstable as the arc control is functioned.

5-4. Remote Control (Option)

You can connect the remote controller to the remote control connector to enable remote operation of weld current adjustment.

- 1) Remove the remote control cover from the operation panel. (6-M4 screws)
- 2) Connect the plug of the extension cord (cord reel) into one of the dedicated remote control connector (side A or B).
- 3) Connect the plug of the remote controller into the receptacle of the extension cord (cord reel). Up to 3 cord reels (30 m x 3) can be connected.

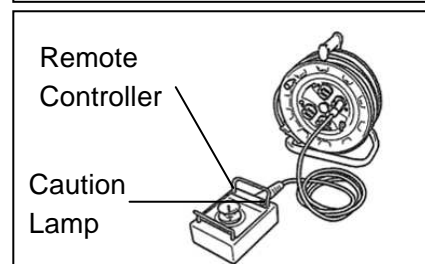
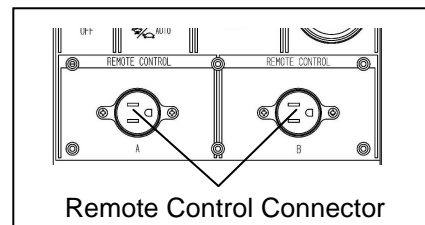

<Note>

- The output control dial on the remote controller connection side of the equipment does not function when a remote controller is connected.
- If the remote controller is disconnected from the remote control connector while welding, the equipment output control dial becomes functional, possibly resulting in an increase or decrease in weld current.
- Do not connect the remote controller plug to the receptacle of an extension cord (cord reel) that is connected to AC power source. Improper connection causes the caution lamp of the remote controller to light up indicating a fault.
- Do not connect the receptacle of an extension cord (cord reel) used for the remote control to any other device besides the remote controller.
- Set the breaker to "ON" if the cord reel is equipped with one.

5-5. Meter

The equipment includes a DC meter that provides digital display of both weld current and voltage, and an AC meter that provides digital display of both voltage and frequency of 3-phase generated output.

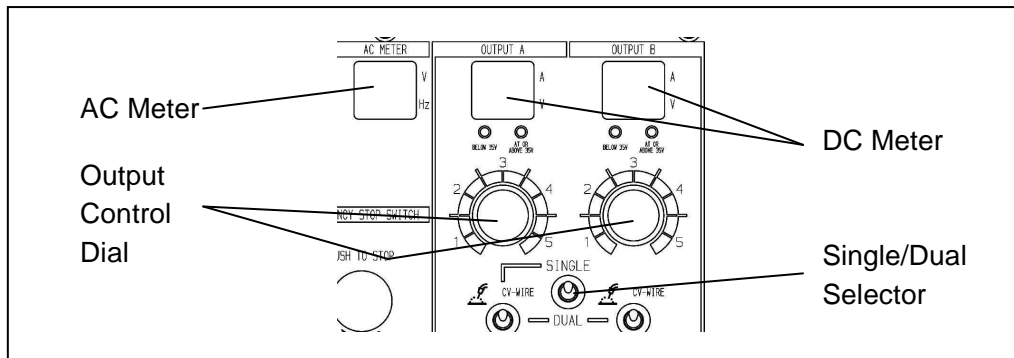

(1) DC Ammeter – Voltmeter

The DC ammeter and voltmeter display the weld output for both outputs A and B separately.

If the single/dual selector is set to "SINGLE", the DC meter for output B does not display current or voltage.

<Note>

- If the weld mode selector is set to "CV-WIRE", the set voltage that has been pre-set using the output control dial is displayed by the voltmeter when not welding. (The DC ammeter display is blank when not welding.)
- If the weld mode selector is set to "CC-STICK", the set current that has been pre-set using the output control dial is displayed by the DC ammeter when not welding. (The voltmeter display is blank when not welding.)
- During welding, both the DC ammeter and voltmeter display the actual output values. When welding is completed, both meters display the actual output values for approximately 8 seconds, after which display returns to the pre-set values.

(2) AC Meter

The AC meter displays of both 3-phase voltage and frequency.

<Note>

- During operation, the AC meter displays constantly the 3-phase output voltage of the AC power source regardless of whether the breaker is set to "ON" or "OFF".

5-6. Error Code Display

The equipment includes an error code display function that notifies the operator of any errors during operation. If an error is detected during operation, error codes are displayed by the DC and AC meters. If this occurs, stop operation immediately, and inspect and repair the location where the error has occurred.

(Refer to section "13.Troubleshooting".)

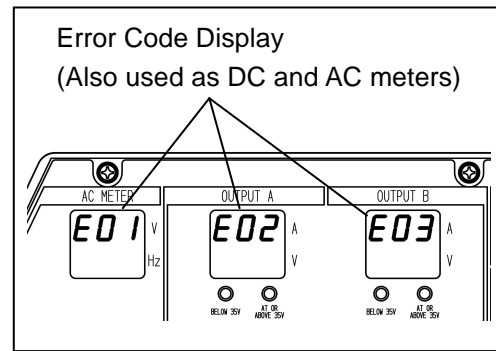

5-7. Monitor Lamp

Warning: Injury/Electric Shock

- Do not operate the equipment with any doors or covers open. There is a danger of hair, body parts and other items being caught up in moving parts such as cooling fans and belts.

Caution: Burn

- The engine, muffler and similar parts are extremely hot during operation and immediately after stopping the equipment. Never touch hot parts.
- Never open the radiator cap during operation or immediately after stopping the equipment. Hot cooling water and steam will spurt out.
- Always be sure to stop the engine and allow it to cool before inspecting or changing the engine oil. Opening the oil gauge or oil plug during operation will result in hot oil spurting out.

The equipment includes monitor lamps for "WATER TEMP", "CHARGE", "OIL PRESS" and "OVERHEAT".

If the equipment is normal, the "CHARGE" and "OIL PRESS" monitor lamps light up when the starter switch is switched from "STOP" to "RUN", and all monitor lamps turn off when the engine is started. If any error besides that of overheating occurs during operation, the corresponding monitor lamp lights up and the engine is automatically stopped.

If the engine is automatically stopped, return the starter switch to "STOP" and restart the engine. Watch the lit/unlit status of the monitor lamps the next time an automatic stop occurs and check the error contents.

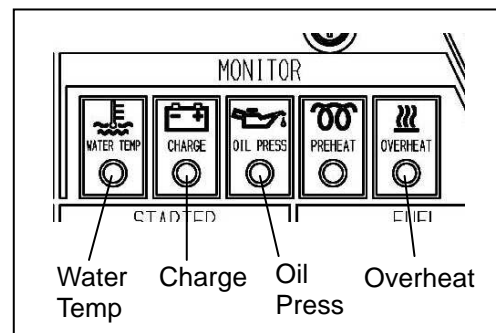

(1) Water Temperature Monitor Lamp

The water temperature monitor lamp ("WATER TEMP") lights up and the engine is automatically stopped if the cooling water temperature becomes irregularly high during operation. If this occurs, inspect the water level of the sub tank and add cooling water if the water level is insufficient. (Refer to section "6-2. Cooling Water Inspection".)

If the cooling water in the sub tank is at the specified level, it is probable that overloading is the cause. Use within the rated output.

(2) Battery Charge Monitor Lamp

The battery charge monitor lamp ("CHARGE") lights up and the engine is automatically stopped if battery charge fails during operation. If this occurs, it is probable that there is fan belt damage or a wiring fault. Request repair at the retail outlet where the equipment was purchased.

(3) Oil Pressure Monitor Lamp

The oil pressure monitor lamp ("OIL PRESS") lights up and the engine is automatically stopped if the engine oil pressure drops during operation. If this occurs, inspect the engine oil level and fill with engine oil until it reaches the maximum level.

<Note>

- The oil pressure monitor cannot detect oil deterioration. Change the engine oil periodically. (Refer to section "11.(1) Changing the Engine Oil" .)
- The charge monitor cannot detect battery deterioration or insufficient battery fluid. Inspect the battery fluid level periodically. (Refer to section "6-6. Battery Inspection".)
- Inspect the fuses if the engine is automatically stopped and none of the monitor lamps ("WATER TEMP", "CHARGE" and "OIL PRESS") light up. (Refer to section "4. Part Names" for fuse location.)

If a fuse has blown, it is probable that there is a fault in an electric part or the wiring. Request repair at the retail outlet where the equipment was purchased.

(4) Overheat Monitor Lamp

The overheating monitor lamp ("OVERHEAT") flash and the equipment cuts the output if the equipment is used excessively over the duty cycle or output. Then it is probable that overloading is the cause. Use within the rated duty cycle or output. (Refer to section "13. Troubleshooting" for Error Code Display.)

<Note>

- There may be a case that the lamp will not flash, depending on the welding type or the weather condition.

5-8. Frequency Selector

Warning: Injury/Electric Shock

- Do not operate the equipment with any doors or covers open. There is a danger of hair, body parts and other items being caught up in moving parts such as cooling fans and belts.

Caution: Burn

- The engine, muffler and similar parts are extremely hot during operation and immediately after stopping the equipment. Never touch hot parts.

Caution: Physical and Secondary Damage

- Set the frequency in accordance with the devices using the equipment.

This equipment can operate at either 50Hz or 60 Hz.

Set the frequency selector located inside the side door to change the frequency in accordance with the devices using the equipment.

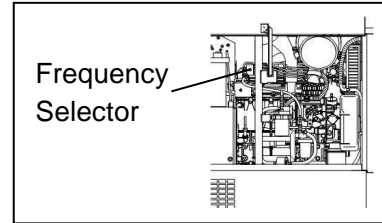
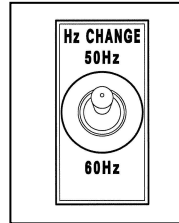

5-9. Ground Fault Circuit Interrupter (GFCI) and Grounding

⚠ Warning: Electric Shock

- Always be sure to repair the corresponding ground fault location when ground fault circuit interrupters operate.

⚠ Warning: Fire

- Do not ground wiring of ground fault circuit interrupters of the equipment to piping that passes through flammable material.

The equipment is provided includes ground fault circuit interrupters (solidly grounded type) in order to prevent electric shock. Immediately isolate the electrical circuit if ground fault occurs due to insulation failure in devices using the equipment or similar reason.

<Note>

- The GFCI receptacles are protected by the ground fault circuit interrupters. The 3-P/1-P output terminal is not protected by the ground fault circuit interrupters.

(1) Operation Check of Ground Fault Circuit Interrupters

Be sure to always check the ground fault circuit interrupters before starting operation according to the following procedures.

- 1) Start the engine. (Refer to section "7-1. Starting the Engine".)
- 2) Set the idle control switch to "HIGH".
- 3) Turn all breakers (main and 1-P) to "ON".
- 4) Press the GFCI receptacle test button. Operation is normal if the GFCI receptacle reset button pop out this time.
- 5) Press the GFCI receptacle reset button until it stays in.

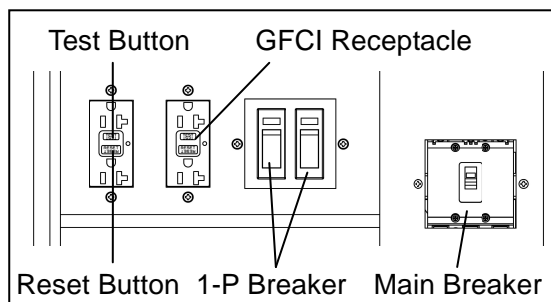
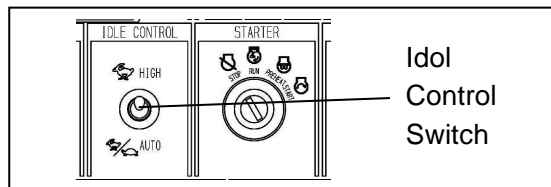

There is a fault in the ground fault circuit interrupters if operation cannot be checked according to the above procedures. Request repair at the retail outlet where the equipment was purchased.

(2) Bonnet grounding terminal

The equipment includes a bonnet grounding terminal in order to connect bonnet ground wire. A neutral point of the AC power source is connected to the bonnet grounding terminal.

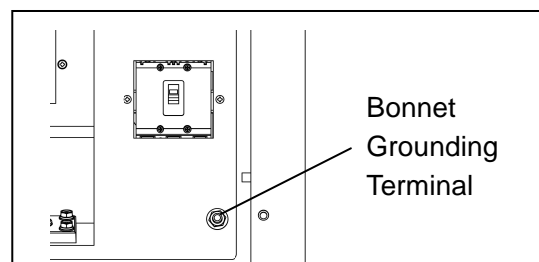

<Note>

- Connect using a plug with a grounding pole.
- If using a plug without a grounding pole, perform grounding work and check that used devices are connected to ground.
- Securely ground the bonnet grounding terminal to the metal frame of the vehicle if transporting the equipment by truck or trailer.

(3) If a Ground Fault Circuit Interrupter Operates

⚠ Caution: Electric Shock/Injury

- Always be sure to turn off the power switches of all devices using the equipment when turning on the equipment breakers after a ground fault circuit interrupters operates. Leaving on the power switch of a device using the equipment when the equipment breaker is turned on could result in the sudden operation of the corresponding device.

The GFCI receptacle reset button pop out when a ground fault circuit interrupters operate. When this occurs, immediately stop the engine and repair the ground fault location.

After repairing all faults, press the GFCI receptacle reset button until it stays in.

<Note>

- There is a fault in the ground fault circuit interrupters if the GFCI receptacle LED lamp flush and reset button pop out. Request repair at the retail outlet where the equipment was purchased.

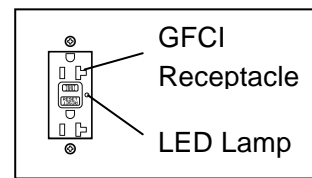

5-10. Emergency Stop Switch

Press the emergency stop switch to stop the engine immediately.

After pressing the emergency stop switch, securely return the starter switch to the "STOP" position and turn the emergency stop switch clockwise to reset the switch.

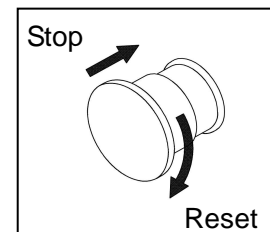

6. Pre-Operation Inspection

⚠ Warning: Injury/Electric Shock

- Do not operate the equipment with any doors or covers open. There is a danger of hair, body parts and other items being caught up in moving parts such as cooling fans and belts.
- Always be sure to stop the engine and remove the starter key before performing any equipment check or maintenance.

⚠ Warning: Fire

- Always be sure to wipe up any spilled fuel or oil.
- Absolutely never use the equipment if there is a fuel, oil or cooling water leak, and be sure to always repair the leak before using.
- Absolutely never inspect or perform maintenance to the equipment near fire or other open flame.

⚠ Caution: Burn

- The engine, muffler and similar parts are extremely hot during operation and immediately after stopping the equipment. Never touch hot parts.

6-1. Engine Oil Inspection

⚠ Caution: Burn

- Always be sure to stop the engine and allow it to cool before inspecting or changing the engine oil. Opening the oil gauge or oil plug during operation will result in hot oil spurting out.

Situate the equipment on a level surface and completely insert the oil gauge to inspect the oil level.
Inspect the oil level before starting operation and, if it has decreased, fill with oil until it reaches the maximum level.

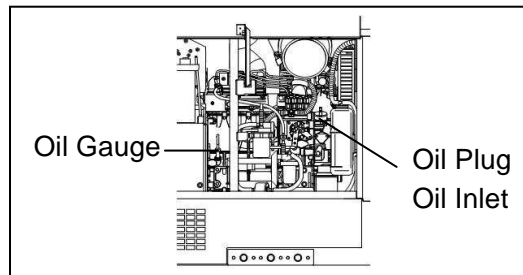

<Note>

- The oil level cannot be accurately checked if the equipment is at an angle.
- Operating the equipment when the oil has been filled above the maximum level can result in engine cylinder internal damage.

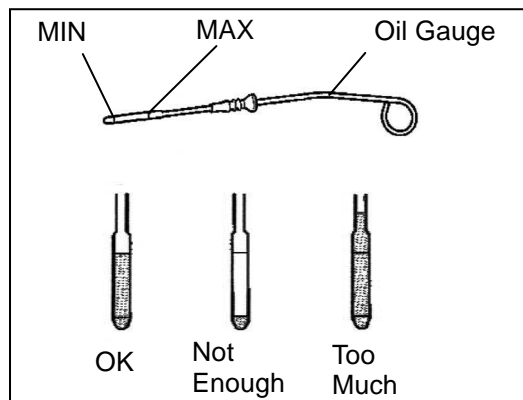

■ Engine Oil Selection

Use a diesel-type engine oil with a viscosity that is appropriate for the outdoor air temperature (refer to the table).

<Note>

- Use oil with a quality of CD class or better (API classification).

Temperature/Engine Oil Relationship

Temperature	+20°C or more	+10°C~+20°C	-10°C~+40°C
Oil Viscosity	SAE30	SAE20	SAE 10W/30

6-2. Cooling Water Inspection

⚠ Caution: Burn

- Never open the radiator cap during operation or immediately after stopping the equipment. Hot cooling water and steam will spurt out.

Check that the sub tank cooling water level is within the range of "FULL" and "LOW".
If the cooling water level is lower than "LOW", add water to both the sub tank and radiator.

(1) Adding Water to the Sub Tank

- 1) Remove the sub tank cap.
- 2) Pour cooling water into the sub tank until it reaches the "FULL" level.
- 3) Install the sub tank cap.

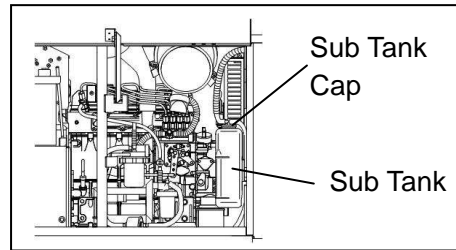

(2) Adding Water to the Radiator

- 1) Open the top plate.
- 2) Remove the radiator cap.
- 3) Pour cooling water into the radiator through the inlet port until it reaches the mouth of the port.
- 4) Tighten the radiator cap.
- 5) Close the top plate.

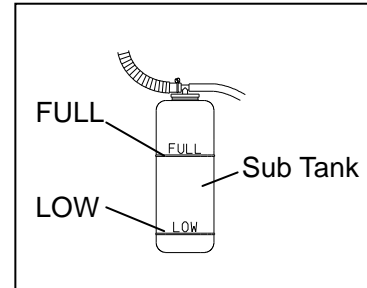

<Note>

- Use a long-life coolant (LLC) in order to prevent freezing and rust. (An LLC with a 30% mixing ratio is used when shipped from the factory.)
- Use an LLC mixing ratio in the range 30% to 45% in accordance with the outdoor air temperature.
- Change the LLC every 2,000 hours or 1 year.

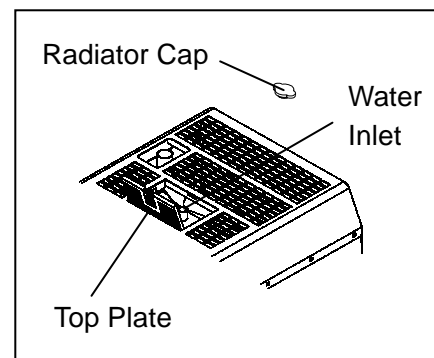

Mixing Ratio Guide

Min. Temp.	-15°C	-20°C	-30°C
Mixing Ratio	30%	35%	45%

6-3. Fuel Inspection

Warning: Fire

- Always be sure to stop the engine when inspecting fuel or refueling, and absolutely never perform such tasks near fire or other open flame. Wait until the engine has completely cooled before inspecting fuel or refueling.

Check that there is sufficient fuel and add fuel if insufficient.

After refueling, securely tighten the tank cap and close the fuel inlet cover.

<Note>

- Use ASTM D975 No. 2-D diesel fuel. Do not use a substitute fuel of unknown quality as this can negatively affect the engine.
- Use a cold-weather fuel that conforms to ASTM standards if using the equipment in a cold weather region.
- Shindaiwa recommends using a fuel with a sulfur content of less than 1,000 ppm.

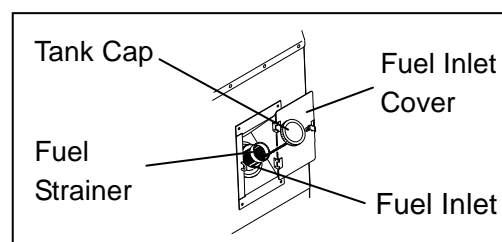

- Change the engine oil and oil filter after a shorter period than normal (approximately one-half the normal period) if using a high-sulfur (sulfur content of between 5,000 to 10,000 ppm) fuel.
- Do not use a fuel with a sulfur content of 10,000 ppm or more. Ultra-low sulfur fuel must be used if using the equipment in a region subject to EPA exhaust gas regulations. Use No. 2-D S15 in place of No. 2-D in such areas. Use No. 1-D S15 in place of No. 1-D in regions where the temperature is -10°C or less.
- Always be sure to use the fuel strainer attached to the fuel inlet.
- Add fuel until the tank is slightly less than full.

6-4. Inspection for Fuel/Oil/Cooling Water Leakage

⚠ Warning: Fire

- Absolutely never use the equipment if there is a fuel, oil or cooling water leak, and be sure to always repair the leak before using.

Open the side door and check for fuel leakage from fuel line joints and similar components, and check for oil and cooling water leakage. Open the fuel tap to perform inspection and close it after inspection has been completed.

6-5. Battery Inspection

⚠ Warning: Injury to Eyes and Skin

- Use protective gear, such as rubber gloves, when inspecting or replacing the battery due to the dilute sulfuric acid in the battery fluid. Be sure that fluid does not get into eyes, or on skin or clothing.
- If battery fluid gets into the eyes, or on the skin or clothing, immediately wash with a large amount of water, and always be especially sure to seek medical attention if it gets into the eyes.

⚠ Warning: Explosion

- Do not operate the equipment or recharge the battery when the battery fluid level is below the lower level.
- Do not generate any sparks near the battery and do not allow any fire or other open flame near the equipment because the battery generates ignitable gas.

- 1) Inspect the battery fluid level. If it is near the lower level, add distilled water until it reaches the upper level.
- 2) Inspect for loose terminals and retighten if loose.

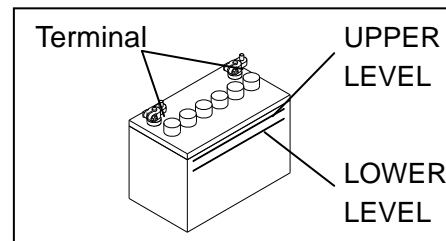

<Note>

- It is necessary to recharge the battery when the specific gravity of the battery fluid is 1.23 or less. Contact the retail outlet where the equipment was purchased if this occurs.

■ Battery Replacement Procedures

- 1) Remove the "-" (negative) cable.
(Always be sure to first remove the "-" (negative) side.)
- 2) Remove the battery hold-down clamp.
- 3) Remove the "+" (positive) cable.
- 4) Remove the battery.

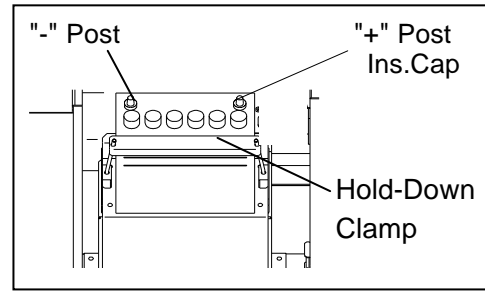

- * Install the battery by performing the above procedures in reverse order. (Always be sure to first attach the "+" (positive) side.)

<Note>

- Use the specified battery. <75D31R> (Japanese Industrial Standard)

7. Operating Procedures

⚠ Warning: Suffocation from Exhaust Fume

- Do not operate the equipment in a poorly-ventilated area such as indoors or within a tunnel because the engine exhaust fume includes components that are harmful to humans.

⚠ Warning: Fire

- Keep any ignitable items (such as fuel, gas and paint) or inflammable items away from the equipment because the muffler, exhaust fume and other parts attain high temperatures.
- Provide at least 1 meter (3 feet) of distance between the equipment and walls and other obstacles, and operate the equipment on a flat surface.

⚠ Caution: Suffocation from Exhaust Fume

- Do not direct the engine exhaust towards passersby, private homes or similar persons/locations because the engine exhaust fume includes components that are harmful to humans.

⚠ Caution: Burn

- The engine, muffler and similar parts are extremely hot during operation and immediately after stopping the equipment. Never touch hot parts.

⚠ Caution: Injury

- Use this equipment with it situated on a stable level surface so that it is prevented from moving.
- Do not move the equipment during operation.
- Always be sure to turn off the switches of all devices using the equipment and turn off the equipment breakers before starting the engine.

<Note>

- Check that the surrounding area is safe before starting the engine.
- When there are multiple workers who are working together, they must mutually signal each other before starting the engine.
- Do not use in an area with high temperature or humidity, or an area with a large amount of dust.
- Do not open any doors during operation. Operating with a door open can negatively affect cooling effect, resulting in an equipment malfunction.
- Use ear protection if the level of noise is high. Failure to do so could result in hearing damage.

7-1. Starting the Engine

- 1) Turn all breakers (main and 1-P) to "OFF".
- 2) Turn the fuel lever (on the fuel filter and water separator) to "OPEN".
- 3) Set the idle control switch to "AUTO".
- 4) Check that the emergency stop switch has been released.
- 5) If the temperature is 5°C or less, turn the starter switch to the "PREHEAT" position and wait until the preheat lamp turns off. (Approx. 5 seconds)
- 6) Turn the starter switch to the "START" position to start the starter motor, which then starts the engine.
- 7) After the engine starts, remove your hand from the starter switch.
- 8) Allow the engine to warm up for approximately 5 minutes.

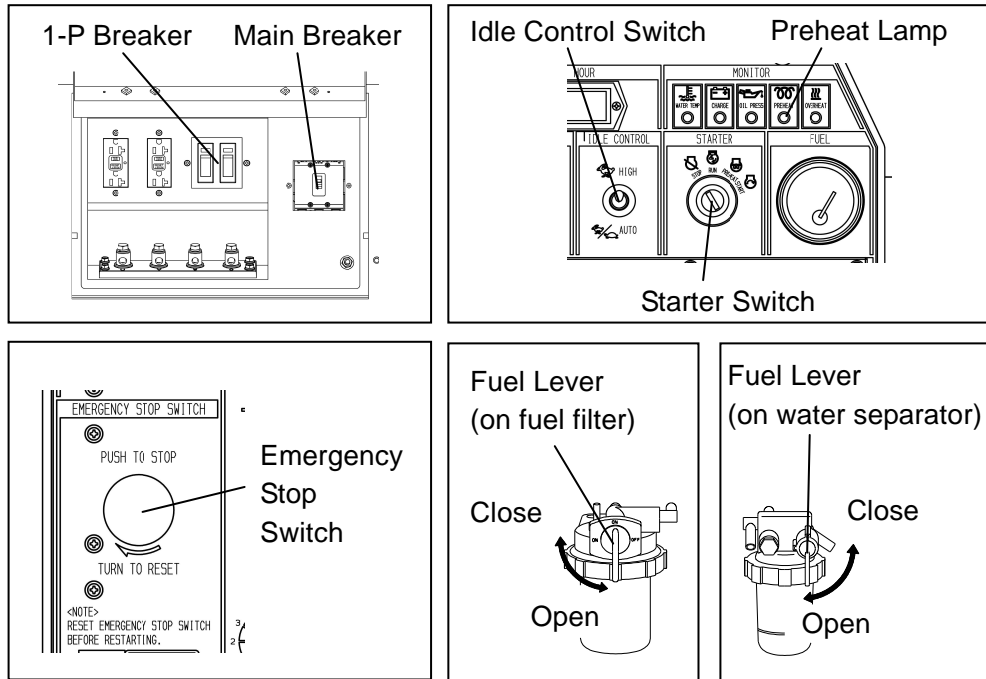

<Note>

- Do not crank the starter motor for 15 seconds or more continuously.
- If repeating starter switch operation, wait 30 seconds or more between operations.
- After the engine starts, do not turn the starter switch to "START" during operation.

■ Restarting after Stopping due to Running Out of Fuel

The equipment includes an automatic air-bleeding device. You can easily restart the engine according to the following procedures even if the engine stops due to running out of fuel.

- 1) Turn all breakers (main and 1-P) to "OFF".
- 2) Turn the starter switch to the "STOP" position.
- 3) Add fuel to the fuel tank.
- 4) Set the idle control switch to "AUTO".
- 5) Turn the starter switch to the "START" position and crank the starter motor for approximately 10 seconds.
- 6) After the engine starts, remove your hand from the starter switch.
- 7) Wait for air to be completely bled from the fuel pipes and engine speed to stabilize (approx. 1 minute). (Engine speed is not stable until all air is bled from the fuel pipes.)

<Note>

- Do not switch the engine to high speed or apply any loads to it until all the air has been bled from the fuel pipes (until speed is stable). Doing so can cause a malfunction.

7-2. Stopping the Engine

- 1) Turn all breakers (main and 1-P) to "OFF".
- 2) Set the idle control switch to "AUTO".
- 3) Allow the engine to cool down for approximately 5 minutes.
- 4) Set the starter switch to "STOP".
- 5) After the engine stops, turn the fuel lever (on the fuel filter and water separator) to "CLOSE".

<Note>

- Do not stop the engine while welding or using as an AC power source. Doing so can cause a malfunction.
- If the engine does not stop when the starter switch is set to "STOP", turn the fuel lever to "CLOSE". The engine will stop a few minutes afterwards. If the engine does not stop by starter switch operation, stop using the equipment and request repair at the retail outlet where the equipment was purchased.

7-3. Emergency Stop

The equipment includes an emergency stop device.

Press the emergency stop switch if you want to immediately stop the engine when an emergency occurs in the work area, the equipment suffers an operating fault, and similar circumstances.

<Note>

- After stopping the engine using the emergency stop device, turn the starter switch to "STOP".
- Do not strike the emergency stop switch with a hammer or similar tool.
- Only use the emergency stop switch for emergency stop purposes.
- If the engine does not stop when the emergency stop switch is pressed, turn the fuel lever to "CLOSE". The engine will stop a few minutes afterwards.

8. Using as a Welder

8-1. Welding Cable Selection

Use welding cables with a cross-sectional area that is larger than the proper cross-sectional areas indicated in the table of the next page.

Using cable that is less than the proper cross-sectional area reduces the weld output.

<Note>

- Use welding cables when they are completely extended (not coiled). Using a cable that is coiled reduces the weld output.

Proper Cable Cross-Sectional Area (Unit: mm²)

Weld Current	Return Length	20m	30m	40m	60m	80m	100m
	500A		38	60	80	125	200
450A		38	60	80	100	150	200
400A		38	50	60	100	125	200
350A		30	50	60	80	125	150
300A		30	38	50	80	100	125
250A		22	30	38	60	80	100
200A		22	30	30	50	60	80
150A		22	22	22	38	50	60
100A		22	22	22	30	30	38

8-2. Welding Polarity

There are "+" (positive) and "-" (negative) weld output terminals.

Refer to the table below to select a polarity corresponding to the work you are performing.

<Note>

- Use the polarity indicated for the welding rods being used if so indicated.
- When welding with 2 persons using different polarities for the same base material, a single worker must not hold 2 holders because the voltage between the 2 holders could become high and there may be a danger.

(1) Shielded Metal Arc Welding, Gouging, Scratch Start TIG

Polarity	Rod Indication	Applications	Connecting Method
Straight Polarity	DC-	<ul style="list-style-type: none"> • Shielded metal arc welding of structures and similar items • Scratch Start TIG Welding 	+ (positive) terminal : Earth (Base material) - (negative) terminal : Holder (welding rod)
Reverse Polarity	DC+	<ul style="list-style-type: none"> • Shielded metal arc welding of laminates, weld overlays, stainless steel and similar materials • Gouging 	+ (positive) terminal : Holder (welding rod) - (negative) terminal : Earth (Base material)

(2) Semi-automatic Arc Welding (MIG, MAG, Self-shielded)

Polarity	Wire Indication	Applications	Connecting Method
Straight Polarity	DC-	<ul style="list-style-type: none"> • Self-shielded Arc Welding 	+ (positive) terminal : Earth (Base material) - (negative) terminal : Torch (wire)
Reverse Polarity	DC+	<ul style="list-style-type: none"> • MIG Welding, MAG Welding • Self-shielded Arc Welding 	+ (positive) terminal : Torch (wire) - (negative) terminal : Earth (Base material)

8-3. Welding Cable Connection

⚠ Warning: Electric Shock

- Be sure to stop the engine whenever touching Weld output terminals such as when installing or removing welding cables.
- Do not connect welding cables to any part other than weld output terminals.

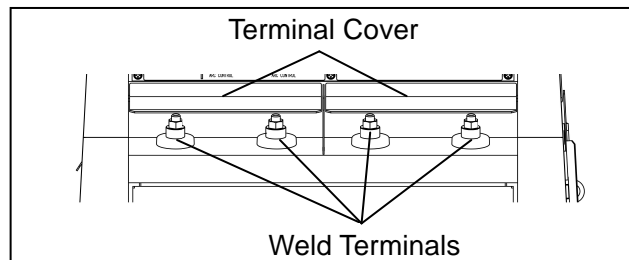
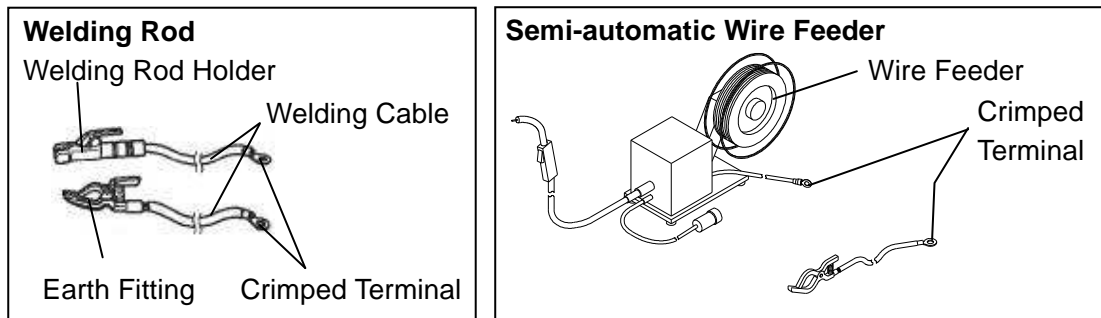

- 1) Stop the engine.
- 2) Install the welding cables, crimped terminals, welding rod holders (or wire feeder) and earth fittings.
- 3) Connect the welding cables to the weld terminals.
(Refer to the table below for cable connection locations.)
- 4) Close the terminal covers.

Amount of Welding Personnel and Welding Cable Connection Locations

Shielded Metal Arc Welding/Gouging		Semi-automatic Arc Welding	
Single	Dual	Single	Dual
Welding Rod $\phi 2.6 - \phi 8.0$ mm	Welding Rod $\phi 2.0 - \phi 6.0$ mm	Welding Wire MIG/MAG: $\phi 0.6 - \phi 1.6$ mm	Welding Wire MIG/MAG: $\phi 0.6 - \phi 1.2$ mm
Gouging Rod $\phi 3.2 - \phi 9.5$ mm	Gouging Rod $\phi 3.2 - \phi 5.0$ mm	Self-shielded: $\phi 0.9 - \phi 2.4$ mm	Self-shielded: $\phi 0.9 - \phi 2.0$ mm
Weld Terminals A	Weld Terminals A or B	Weld Terminals A	Weld Terminals A or B

<Note>

- Securely crimp the crimped terminals and securely connect the welding cables. Using insufficiently crimped terminals or loosely connected cables can result in heat generation from poor connection, thereby causing burnout of the weld output terminals.
- Be sure to always securely crimp the crimped terminals on the cables connected to the Weld output terminals. Not using crimped terminals and simply wrapping stripped cable around the Weld output terminal can result in heat generation from poor connection, thereby causing burnout of the Weld output terminals and a short circuit due to contact of the cable core with the equipment body.
- Keep your welding cable and electrode holder in good condition. Repair or replace any damaged insulation.

8-4. Duty Cycle

The duty cycle is the percentage of time the load is being applied in a 10-minute period. For example a 60% duty cycle, represents 6 minutes of load and 4 minutes of no-load in a 10-minute period.

<Note>

- Continuing to weld beyond the rated duty cycle with the rated output can result in equipment overheating and corresponding malfunctions.

8-5. Welding Work

⚠ Warning: Suffocation from Welding Fume

- Always be sure to wear a fume-proof mask when welding as the fumes generated during welding include harmful gases and dust. Also be careful that the wind direction is not such that it will cause fumes to be inhaled and always operate the equipment in a well-ventilated area.

⚠ Warning: Fire

- Keep any ignitable items (such as fuel, gas and paint) or inflammable items away from the work area due to the scattering of weld spatter that occurs during welding.

⚠ Warning: Electromagnetic Interference

- Persons using a heart pacemaker are not allowed near the welder or welding work area while welding is being performed without the permission of a doctor. The welder generates a magnetic field while energized that can negatively affect pacemaker operation.

⚠ Caution: Injury to Eyes and Skin

- Always be sure to wear arc-proof glasses (refer to the table below), clothes that completely cover the skin and other protective gear when welding to protect the eyes and skin from harmful light rays generated during welding.

Standards for Arc-Proof Glasses (Japanese Industrial Standard)

Filter No.		7	8	9	10	11	12	13	14
Weld Current (A)	Shielded metal arc welding	35-75		76-200		201-400			400-
	Gas-shielded arc welding	—	—	100 or less		101-300		301-500	
	Gouging	—	—	—	126-225		226-350		—

- Always be sure to wear leather gloves, apron, shoe covers, arc-proof glasses (face shield), safety shoes, hard hat and long-sleeve clothing to protect against the scattering of weld spatter that occurs during welding.

⚠ Caution: Electric Shock

- If wearing gloves, be sure to always wear gloves with dry insulation properties. Do not wear gloves that are damaged or wet.

You can select from among 3 weld modes in accordance with the type of welding being performed. Select a weld mode by referring to the recommended modes in the table below.

Weld Modes Table (Recommended)

Mode Name		Applications	Welding Position
CV	-WIRE	•Semi-automatic Arc Welding (MIG, MAG, self-shielded, and similar welding)	All directions
CC	CELLULOSE/ SCRATCH START TIG	•Welding of structures and finishing welding •TIG welding	Horizontal and Downward
	STANDARD/ GOUGING	•Welding of heavy structures and thick plates •Gouging	

<Note>

- This equipment allows for 2 person simultaneous welding. For 2 person simultaneous welding, select a weld mode and adjust the weld output in accordance with each type of welding work being performed.
- The range of weld output that can be adjusted using the output control dial varies depending on the positions of the single/dual selector and weld mode selector. (Refer to section "2. Specifications".)

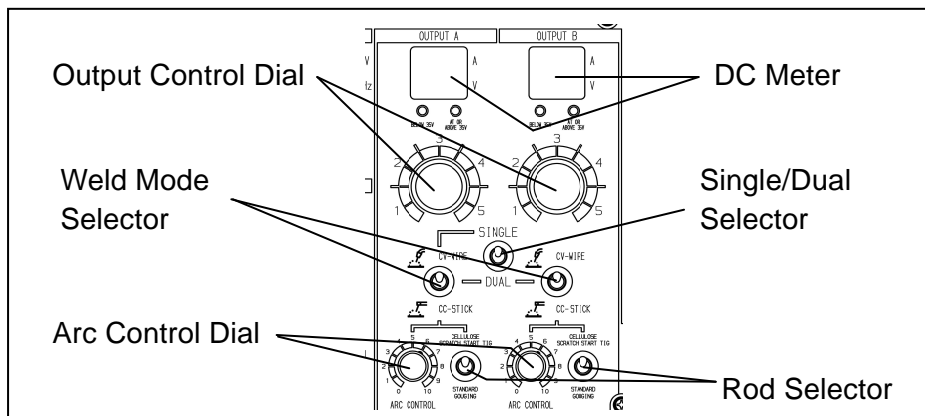

(1) Semi-automatic Arc Welding

- 1) Set the weld mode selector to "CV-WIRE".
- 2) Switch the single/dual selector in accordance with the amount of welding personnel and desired weld output.
- 3) Set the output control dial to the desired voltage.
- 4) Start the engine. (Refer to section "7-1. Starting the Engine".)
- 5) Set the wire feed speed of the wire feeder.
- 6) While an arc is being generated, adjust the output control dial of the equipment or remote controller so that the arc is stabilized.

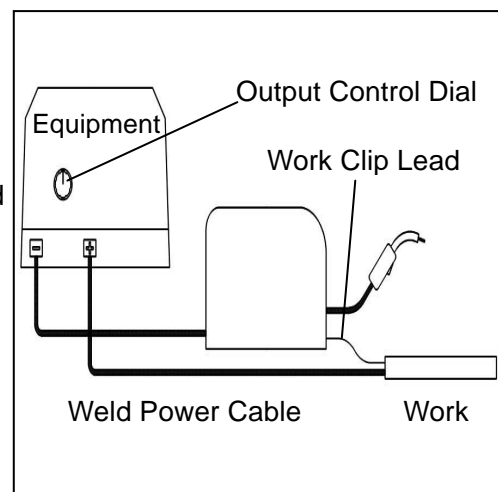

(2) Shielded Metal Arc Welding, Gouging, Scratch Start TIG

- 1) Switch the single/dual selector in accordance with the amount of welding personnel and desired weld output.
- 2) Switch the weld mode selector and the rod selector in accordance with the work being performed.
- 3) Adjust the output current using the output control dial.
- 4) If using "CC-STICK" weld mode, adjust the arc strength using the arc control dial.

<Note>

- The value selected using the output control dial is displayed by the DC meter. During welding, both the DC ammeter and voltmeter display the actual output values. When welding is completed, both meters display the actual output values for approximately 8 seconds, after which display returns to the set values.
- The arc control function is only for "CC-STICK" mode. It does not function if using "CV-WIRE".

9. Using as a Generator

9-1. Output Types and Ranges

(1) Output Types

■ 3-Phase 200/220V Output

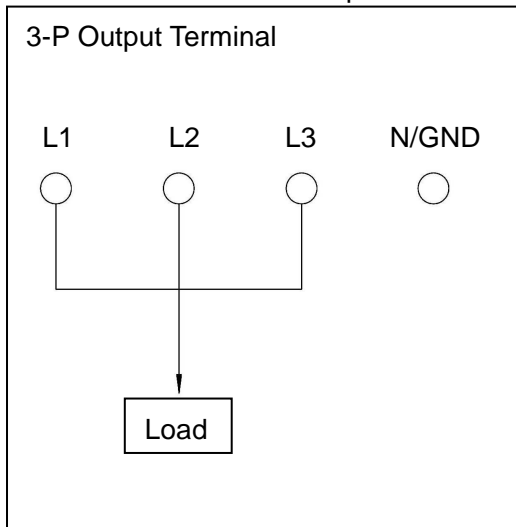

■ 1-Phase 200/220V Output

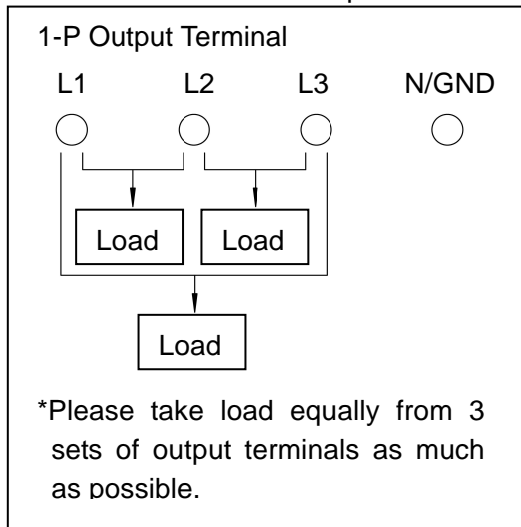

■ 1-Phase 115/127V Output

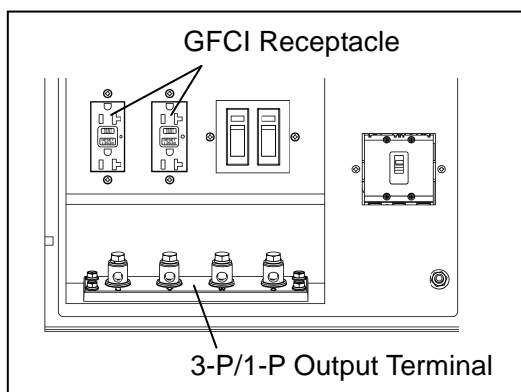
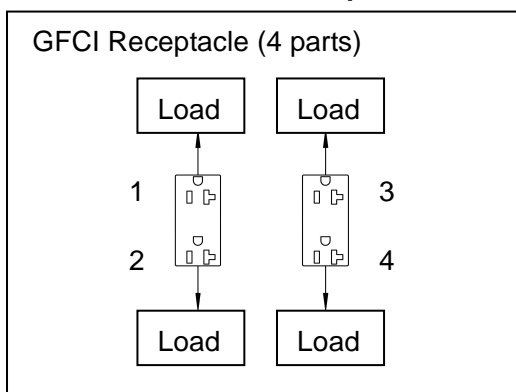

(2) Output Ranges

It can be used to the following output. (Units: kVA)

(50/60Hz)

3-Phase 200/220V	1-Phase 200/220V			1-Phase 115/127V	
	L1-L2	L2-L3	L1-L3	Receptacle	
				1+2	3+4
9.9 / 9.9	5.7 / 5.7	5.7 / 5.7	5.7 / 5.7	2.3 / 2.5	2.3 / 2.5
	total : 8.0 / 8.0			total : 4.6 / 5.1	

9-2. Usable Device Capacities

Usable capacity varies depending on the type and performance of the electrical tool or household appliance being used.

Overview of Usable Device Capacities

(50/60Hz)

Device Used	Standard Capacities (Units : kW)				
	1-Phase 115/127V		1-Phase 200/220V		3-Phase 200/220V
	Capacity per one Receptacle	Total capacity of four Receptacles	Capacity per one set of Output Terminal	Total capacity of three set of Output Terminals	Capacity per one Output Terminal
Incandescent bulbs, electrical heaters and similar devices	2.3 / 2.5	4.6 / 5.1	5.7 / 5.7	8.0 / 8.0	—
Electrical tools (commutator motor) and similar devices	1.2 / 1.3	2.3 / 2.5	2.9 / 2.9	4.0 / 4.0	—
Mercury lamps (high power factor types)	0.9 / 1.0	1.8 / 2.0	2.3 / 2.3	3.2 / 3.2	—
Submerged pump, compressor and similar devices (Induction motors)	0.9 / 1.0	1.8 / 2.0	2.3 / 2.3	3.2 / 3.2	4.0 / 4.0

* Commutator motors: Motors with brushes

* Induction motors: Motors without brushes

* Capacity values are displayed under "OUTPUT" for induction motors and under "POWER CONSUMPTION" for all other devices.

<Note>

- Be sure to use the frequency designated in the equipment incorporated in mercury bulb or induction motor.
- Devices using a motor might require power that is larger than the device rating. In such cases, consult with the retail outlet where the equipment was purchased.
- Do not start up multiple devices simultaneously if using two or more units of devices such as submerged pumps. Start each unit separately.
- Do not light up a mercury lamp again immediately after turning it off. Wait for the lamp to cool down (approximately 15 minutes) after a lamp has been turned off before turning it on again.

9-3. Operation

⚠ Warning: Electric Shock

- Always be sure to turn off all breakers before installing or removing devices using AC output receptacles and AC output terminals.
- Always be sure to repair the corresponding ground fault location when ground fault circuit interrupters operate.

⚠ Caution: Injury

- Always be sure to turn off the power switches of all devices using the equipment when turning on the equipment breakers. Leaving on the power switch of a device using the equipment when the equipment breakers are turned on could result in the sudden operation of the corresponding device.
- Do not leave on the power switch of a device using the equipment and do not connect a device to an AC output receptacles and an AC output terminals.

⚠ Caution: Physical and Secondary Damage

- If using the equipment as a power source for medical equipment, you must check with the medical equipment manufacturer, doctor and hospital before using the equipment.
- Set the frequency in accordance with the devices using the equipment.

- 1) Switch the frequency selector in accordance with the devices using the equipment. (Refer to section "5-8. Frequency Selector" .)
- 2) Turn off the switches of devices being used.
- 3) Turn all breakers (main and 1-P) to "OFF".
- 4) Start the engine. (Refer to section "7-1. Starting the Engine".)
- 5) Connect the power plug(s) of device(s) being used to the AC output receptacle(s) or the load(s) to the AC output terminal(s).
- 6) Turn all breakers (main and 1-P) to "ON".

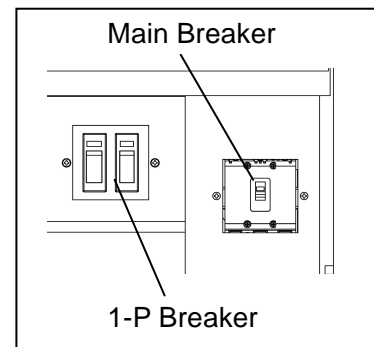

<Note>

- During operation, the AC meter displays constantly the 3-phase output voltage of the AC power source regardless of whether the breaker is set to "ON" or "OFF".

■ Recovery from Overcurrent Breaker Operation

⚠ Caution: Injury

- Always be sure to turn off the power switches of all devices using the equipment when turning on the equipment breakers. Leaving on the power switch of a device using the equipment when the equipment breakers are turned on could result in the sudden operation of the corresponding device.

Breakers operate when there is excessive current to isolate the corresponding circuit.

Inspect the breakers if a device being used stops during equipment operation.

Follow the following procedures to recover operation when breakers operate due to overcurrent.

- 1) Turn off all switches of devices using the equipment as an AC power source.
- 2) Push up the breaker lever that has operated to the "ON" position.

<Note>

- Refer to section "9-2. Usable Device Capacities" and be careful of overloading.

10. Simultaneously Welding and Using as AC Power Source

Due to the fact that breakers only function for AC power output, the engine can become overloaded if simultaneously welding and using the equipment as an AC power source.

Refer to the table below and limit the use of AC power accordingly.

Overview of Capacities Usable Simultaneously (50/60Hz)			
Weld Output		AC Power Output	
Amount of Personnel	Current	3-phase Output (Power factor : 0.8)	1-phase Output (Power factor : 1.0)
Used by 1 Person [SINGLE] or [DUAL]	70A	9.9 / 9.9 kVA	8.0 / 8.0 kW
	100A	9.9 / 9.9 kVA	8.0 / 8.0 kW
	150A	9.9 / 9.9 kVA	8.0 / 8.0 kW
	200A	9.9 / 9.9 kVA	8.0 / 8.0 kW
	250A	9.9 / 9.9 kVA	8.0 / 8.0 kW
	300A	7.5 / 8.0 kVA	6.0 / 7.0 kW
	350A	4.5 / 5.5 kVA	3.5 / 4.5 kW
	400A	1.5 / 2.5 kVA	1.0 / 2.0 kW
	450A	0 / 0 kVA	0 / 0 kW
	500A	0 / 0 kVA	0 / 0 kW
Used by 2 Person [DUAL]	50A×2	9.9 / 9.9 kVA	8.0 / 8.0 kW
	100A×2	9.9 / 9.9 kVA	8.0 / 8.0 kW
	150A×2	9.5 / 9.9 kVA	7.5 / 8.0 kW
	200A×2	5.5 / 5.5 kVA	4.0 / 5.0 kW
	250A×2	1.0 / 1.5 kVA	0.5 / 1.0 kW
	280A×2	0 / 0 kVA	0 / 0 kW

*1-phase output is the total output of 1-phase 115/127V output and 1-phase 200/220V output.

<Note>

- Do use as an AC power source simultaneously with welding if it is necessary to perform high-quality welding.

11. Inspection/Maintenance

⚠ Warning: Electric Shock/Injury

- Do not touch the equipment during operation if the equipment or your body is wet.
- Always be sure to stop the engine and remove the starter key before performing any equipment check or maintenance.
- Do not operate the equipment with any doors or covers open. There is a danger of hair, body parts and other items being caught up in moving parts such as cooling fans and belts.
- Do not modify the equipment and do not operate with parts removed.

⚠ Warning: Fire

- Always be sure to stop the engine when inspecting fuel or refueling, and absolutely never perform such tasks near fire or other open flame. Wait until the engine has completely cooled before inspecting fuel or refueling.
- Always be sure to wipe up any spilled fuel or oil.
- Absolutely never use the equipment if there is a fuel, oil or cooling water leak, and be sure to always repair the leak before using.
- Absolutely never inspect or perform maintenance to the equipment near fire or other open flame.

⚠ Warning: Injury to Eyes and Skin

- Use protective gear, such as rubber gloves, when inspecting or replacing the battery due to the dilute sulfuric acid in the battery fluid. Be sure that fluid does not get into eyes, or on skin or clothing.
- If battery fluid gets into the eyes, or on the skin or clothing, immediately wash with a large amount of water, and always be especially sure to seek medical attention if it gets into the eyes.

⚠ Warning: Explosion

- Do not operate the equipment or recharge the battery when the battery fluid level is below the lower level.
- Do not generate any sparks near the battery and do not allow any fire or other open flame near the equipment because the battery generates ignitable gas.

⚠ Caution: Burn

- The engine, muffler and similar parts are extremely hot during operation and immediately after stopping the equipment. Never touch hot parts.
- Never open the radiator cap during operation or immediately after stopping the equipment. Hot cooling water and steam will spurt out.
- Always be sure to stop the engine and allow it to cool before inspecting or changing the engine oil. Opening the oil gauge or oil plug during operation will result in hot oil spurting out.

<Note>

- Procedures except for pre-operation inspection must be performed by specialized technicians.
- Items indicated by ●: Contact the retail outlet where the equipment was purchased.
- Always be sure to use genuine parts when replacing parts.

- When removing waste liquid from the equipment, place some container to collect the liquid and prevent it from spilling on the ground. Dispose of such oil, fuel, cooling water (LLC), filters, batteries and other harmful substances as industrial waste in accordance with applicable laws and regulations. Consult with the retail outlet where the equipment was purchased if you have any inquiries regarding proper disposal.
- When performing maintenance with doors or covers open, be sure that no other persons can accidentally come close to the equipment. Close all doors and covers if momentarily leaving the equipment unattended.

Perform periodic inspection and maintenance as indicated by the table below in order to ensure that this equipment can be operated in optimal condition.

Use the hour meter as a general indicator for the operating time.

	Inspection Item	Pre-Operation Inspection	Inspection Period					
			50th hour	Every 100 hours	Every 200 hours	Every 400 hours	Every 1,000 hours	Every 2,000 hours
1	Inspect/Add Fuel	○						
2	Inspect/Add Engine Oil	○						
3	Change Engine Oil		1st time ○	2nd time and after ○				
4	Change Oil Filter		1st time ○		2nd time and after ○			
5	Inspect/Add Cooling Water	○						
6	Change Cooling Water							○ or 1 year
7	Clean Fuel Filter		1st time ○	2nd time and after ○				
8	Replace Fuel Element					○		
9	Inspect Water Separator	○						
10	Drain Water from/Clean Water Separator					○		
11	Drain Water from/Clean Fuel Tank				○			
12	Inspect for Fuel/Oil/Cooling Water Leakage	○						
13	Inspect/Add Battery Fluid	○						
14	Clean Air Element		1st time ○	2nd time and after ○				
15	Replace Air Element					○		
16	Adjust V-belt Tension		1st time ●	2nd time and after ●				
17	Replace V-belt					● or 2 years		
18	Clean Radiator Fin (External)					●		
19	Clean Radiator (Internal)					●		

Inspection Item	Pre-Operation Inspection	Inspection Period					
		50th hour	Every 100 hours	Every 200 hours	Every 400 hours	Every 1,000 hours	Every 2,000 hours
20	Replace Fuel/Cooling Water/Oil Hoses and Anti-Vibration Rubber						● or 2 years
21	Adjust/Lap Clearance of Air Intake/Release Valves					● Adjustment	● Lapping
22	Inspect/Adjust Clearance of Fuel Injection Valves				●		
23	Inspect/Adjust Fuel Injection Pump						●

(1) Changing the Engine Oil

1st time	50th hour
2nd time and after	Every 100 hours

- 1) Remove the oil plug.
- 2) Remove the oil drain plug and drain the engine oil.
- 3) Tighten the oil drain plug.
- 4) Add oil through the oil inlet, while checking the oil level using the oil gauge, until it reaches the maximum level. (Fill with approx. 6 L.)
- 5) Tighten the oil plug.

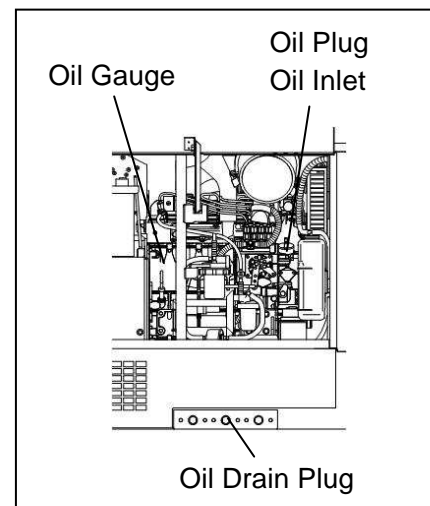

<Note>

- Refer to section "6-1. Engine Oil Inspection" for the types of engine oil.
- Replace the packing of the oil drain plug with a new part each time the oil is changed.
- Packing part no.: 6C090-58961 (Kubota part no.)
- After tightening the oil drain plug, operate the engine for a short period and check that there is no oil leakage. Stop the engine when completed.

(2) Changing the Oil Filter

1st time	50th hour
2nd time and after	Every 200 hours

- 1) Drain the engine oil according to the procedures of "(1) Changing the Engine Oil".
- 2) Remove the oil filter using a filter wrench.
- 3) Apply a thin layer of oil to the gasket of a new oil filter.
- 4) Screw in the oil filter by hand and securely tighten by hand (do not use a filter wrench) after the gasket contacts the seal surface.
- 5) Add engine oil.

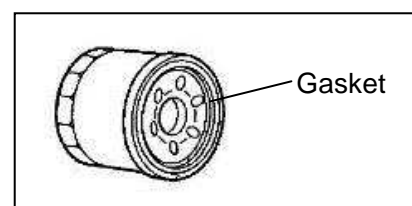
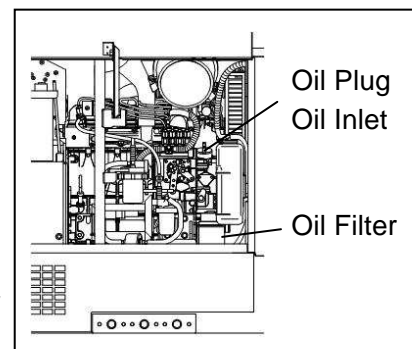

<Note>

- Contact the retail outlet where the equipment was purchased if you do not have a filter wrench.
- Oil filter part no.: 16271-32093 (Kubota part no.)
- After adding engine oil, operate the engine for a short period and check that there is no oil leakage. Stop the engine when completed.

(3) Cleaning/Replacing the Air Element

Cleaning	1st time: 50th hour / 2nd time and after: Every 100 hours
Replacement	Every 400 hours

- 1) Release the air cleaner clips and remove the cleaner cap.
- 2) Clean or replace the air element.
<If dry dust is adhering>
Spray compressed air from within the element.
<If carbon or oily substance is adhering>
Replace with a new part.
- 3) Install in the reverse order of removal.

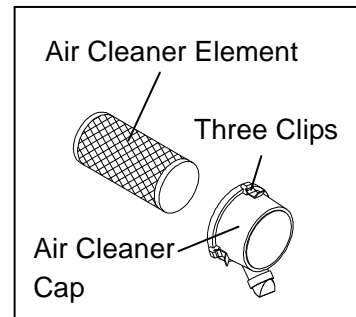
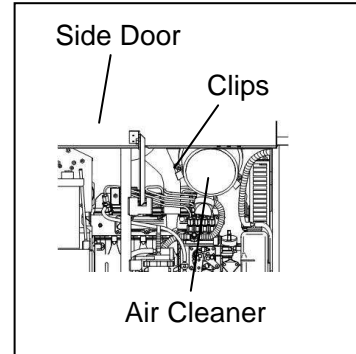

<Note>

- Clean sooner than scheduled if using the equipment in a dusty location.
- Element part no.: R1401-42271 (Kubota part no.)

(4) Cleaning/Replacing the Fuel Filter

Cleaning	1st time: 50th hour / 2nd time and after: Every 100 hours
Replacement	Every 400 hours

- 1) Turn the fuel lever to "CLOSE".
- 2) Turn the retainer ring to the left and remove the cup and element.
- 3) Remove any water or foreign material from the cup and clean the element using compressed air. (Or replace the element.)
- 4) Install in the reverse order of removal.

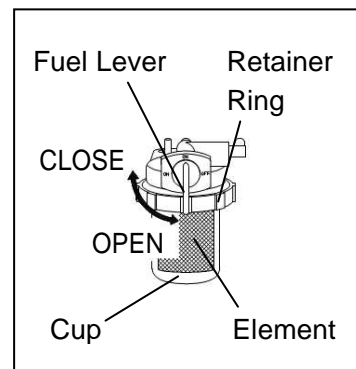
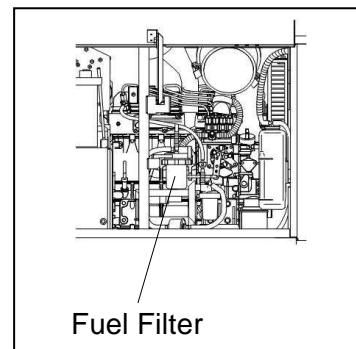

<Note>

- Check that no foreign material is adhering to the packing then install the cup.
- After installation, turn the fuel lever to "OPEN" and check that there is no fuel leakage. After checking, turn the fuel lever to "CLOSE".
- Element part no.: 15521-43161 (Kubota part no.)

(5) Draining Water from the Water Separator

Draining Water	Every 200 hours
----------------	-----------------

When the float (red) is coming up to drain water line, drain the water.

- 1) Turn the fuel lever to "CLOSE".
- 2) Turn the retainer ring to the left and remove the cup and gauze filter.
- 3) Remove any water or foreign material from the cup and clean the element using compressed air.
- 4) Install in the reverse order of removal.

<Note>

- Check that no foreign material is adhering to the packing then install the cup.
- After installation, turn the fuel lever to "OPEN" and check that there is no fuel leakage. After checking, turn the fuel lever to "CLOSE".

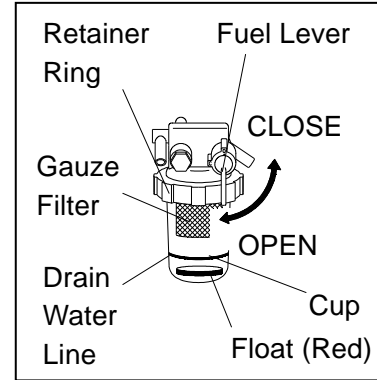
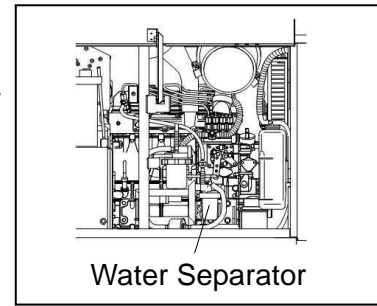

(6) Draining Water from the Fuel Tank

Draining Water	Every 200 hours
----------------	-----------------

- 1) Remove the fuel drain plug.
- 2) Drain the water and tighten the fuel drain plug.

<Note>

- Replace the packing with a new part each time you drain the water.
- Packing part no.: 6C090-58961 (Kubota part no.)
- Always be sure to check that there is no fuel leakage after tightening the fuel drain plug.

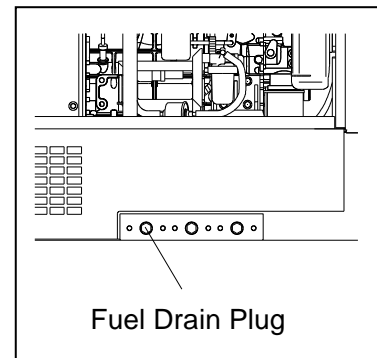

(7) Changing the Cooling Water

Change	Every 2,000 hours or 1 year
--------	-----------------------------

Cooling Water Total Capacity: Approximately 5.6 L (Including the sub tank capacity of approx. 0.8 L)

- 1) Open the top plate.
- 2) Remove the radiator cap.
- 3) Remove the water drain plug.
- 4) Drain the cooling water and tighten the water drain plug.
- 5) Change the cooling water in the sub tank.
- 6) Pour cooling water into the water inlet until it reaches the mouth of the port.
- 7) Tighten the radiator cap.
- 8) Close the top plate.

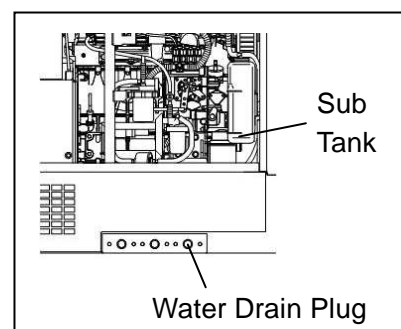
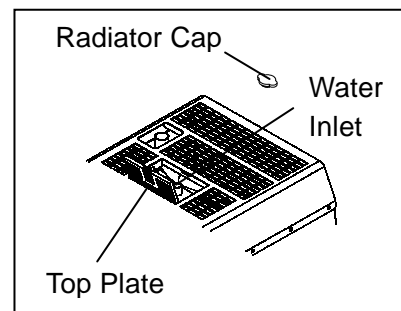

<Note>

- Replace the packing with a new part each time you change the cooling water.
- Packing part no.: 6C090-58961 (Kubota part no.)
- Operate the engine for a short period and check that there is no cooling water leakage. Stop the engine when completed.

12. Long-Term Storage

⚠ Warning: Electric Shock/Injury

- Always be sure to stop the engine and remove the starter key before performing any equipment check or maintenance.
- Do not operate the equipment with any doors or covers open. There is a danger of hair, body parts and other items being caught up in moving parts such as cooling fans and belts.

⚠ Warning: Fire

- Always be sure to stop the engine when inspecting fuel or refueling, and absolutely never perform such tasks near fire or other open flame. Wait until the engine has completely cooled before inspecting fuel or refueling.
- Always be sure to wipe up any spilled fuel or oil.

⚠ Caution: Burn

- The engine, muffler and similar parts are extremely hot during operation and immediately after stopping the equipment. Never touch hot parts.
- Always be sure to stop the engine and allow it to cool before inspecting or changing the engine oil. Opening the oil gauge or oil plug during operation will result in hot oil spurting out.

Perform the following maintenance procedures if not using the equipment for two months or more.

- 1) Remove the battery. (Refer to section "6-5. Battery Inspection".)
- 2) Change the engine oil. (Refer to section "11.(1) Changing the Engine Oil".)
- 3) Drain the fuel from the fuel tank and filter, water separator.
(Refer to section "11.(4) Cleaning/Replacing the Fuel Filter" and "11.(5) Draining Water from the Water Separator".)
- 4) Remove the starter key and store in a secure location.
- 5) Clean all parts and store the equipment in an area with low humidity and little dust with a cover or similar protection covering it.

<Note>

- Recharge a removed battery approximately once every month.

13. Troubleshooting

Warning: Electric Shock/Injury

- Always be sure to stop the engine and remove the starter key before performing any equipment check or maintenance.
- Do not touch the equipment during operation if the equipment or your body is wet.
- Do not operate the equipment with any doors or covers open. There is a danger of hair, body parts and other items being caught up in moving parts such as cooling fans and belts.

Warning: Fire

- Always be sure to stop the engine when inspecting fuel or refueling, and absolutely never perform such tasks near fire or other open flame. Wait until the engine has completely cooled before inspecting fuel or refueling.
- Always be sure to wipe up any spilled fuel or oil.
- Absolutely never use the equipment if there is a fuel, oil or cooling water leak, and be sure to always repair the leak before using.
- Absolutely never inspect or perform maintenance to the equipment near fire or other open flame.

Warning: Injury to Eyes and Skin

- Use protective gear, such as rubber gloves, when inspecting or replacing the battery due to the dilute sulfuric acid in the battery fluid. Be sure that fluid does not get into eyes, or on skin or clothing.
- If battery fluid gets into the eyes, or on the skin or clothing, immediately wash with a large amount of water, and always be especially sure to seek medical attention if it gets into the eyes.

Warning: Explosion

- Do not operate the equipment or recharge the battery when the battery fluid level is below the lower level.
- Do not generate any sparks near the battery and do not allow any fire or other open flame near the equipment because the battery generates ignitable gas.

Caution: Burn

- The engine, muffler and similar parts are extremely hot during operation and immediately after stopping the equipment. Never touch hot parts.
- Never open the radiator cap during operation or immediately after stopping the equipment. Hot cooling water and steam will spurt out.
- Always be sure to stop the engine and allow it to cool before inspecting or changing the engine oil. Opening the oil gauge or oil plug during operation will result in hot oil spurting out.

Refer to the table below to perform inspection when the equipment is operating poorly.

If you cannot resolve a problem after inspecting the equipment, request repair at the retail outlet where the equipment was purchased.

Symptom	Possible Causes	Remedy
Starter motor does not start.	<ol style="list-style-type: none"> 1. Battery has a low charge. 2. Battery is deteriorated. 	<ol style="list-style-type: none"> 1. Recharge the battery. 2. Replace the battery.
Engine does not start.	<ol style="list-style-type: none"> 1. Fuel lever is "CLOSE". (fuel filter or water separator) 2. Emergency stop switch is "ON". 3. No fuel 4. Water or foreign material is mixed in with the fuel. 5. Blown fuse 	<ol style="list-style-type: none"> 1. Turn the fuel lever to "OPEN". (fuel filter and water separator) 2. Release the emergency stop switch. 3. Add fuel. 4. Drain water from and clean the fuel tank and fuel strainer. 5. Replace the fuse.
Engine starts but quickly stops.	<ol style="list-style-type: none"> 1. Insufficient oil 2. Overheating of water temperature 3. Battery recharging fault 	<ol style="list-style-type: none"> 1. Add oil. 2. Comply with rated outputs/Add cooling water. 3. Repair.
Black or white smoke is continuously exhausted from the muffler.	<ol style="list-style-type: none"> 1. Overloaded 	<ol style="list-style-type: none"> 1. Comply with the rated outputs.
Engine does not stop.	<ol style="list-style-type: none"> 1. Stop solenoid fault 	<ol style="list-style-type: none"> 1. Turn the fuel lever to "CLOSE" to stop the engine and repair.
Weak welding arc	<ol style="list-style-type: none"> 1. Single/Dual selector is set to "DUAL". 2. Frequency selector is set to "50Hz" 3. Wrong Output control dial position. 4. Faulty cable connection 5. Improper cable (excessively thin) 6. Faulty connection with base material 7. Using simultaneously as AC power source 8. Welding cable short circuit 	<ol style="list-style-type: none"> 1. Set to "SINGLE". 2. Set to "60Hz". 3. Turn the output control dial clockwise. 4. Connect securely. 5. Replace with cable according to "Welding Cable Selection". 6. Connect securely. 7. Do not use as AC power source. 8. Remove the cause of the short circuit.
Strong welding arc	<ol style="list-style-type: none"> 1. Single/Dual selector is set to "SINGLE". 2. Wrong Output control dial position. 3. Arc control setting is excessively strong. 4. Weld mode selector is set to "CV-WIRE". 	<ol style="list-style-type: none"> 1. Set to "DUAL". 2. Turn the output control dial counterclockwise. 3. Turn the arc control dial the counterclockwise. 4. Set to "CC-STICK".
Wire feeder cannot be used.	<ol style="list-style-type: none"> 1. Weld mode selector is set to "CC-STICK". 	<ol style="list-style-type: none"> 1. Set to "CV-WIRE".
Weld output cannot be adjusted.	<ol style="list-style-type: none"> 1. Remote controller is connected. 	<ol style="list-style-type: none"> 1. Disconnect the remote controller. Or, adjust using the remote controller.
No AC power output	<ol style="list-style-type: none"> 1. Breaker is "OFF". 	<ol style="list-style-type: none"> 1. Turn the breaker to "ON".
AC power output is weak.	<ol style="list-style-type: none"> 1. Wrong frequency 2. The current of devices using the equipment exceed the rated current. 3. Using simultaneously for welding. 	<ol style="list-style-type: none"> 1. Check frequency 2. Refer to "Usable Device Capacities". 3. Stop welding.

Symptom	Possible Causes	Remedy
Engine cannot obtain high speed.	1. Current of device using the equipment as AC power source is 0.5A or less.	1. Set the idle control switch to "HIGH".
Engine cannot obtain low speed.	1. Idle control switch is set to "HIGH". 2. Welding cable short circuit	1. Set to "AUTO". 2. Remove the cause of the short circuit.
Weld output cannot be adjusted by remote controller	1. Connect the AC power source into the remote controller connection.	1. Disconnect the AC power source
VRD does not work.	1. VRD switch is set to "OFF".	1. Set to "ON".

■ Error Code Display

Error codes are displayed on the DC and AC meters when the control board detects an error.

If the error code is displayed, follow to the procedures in the "Remedy".

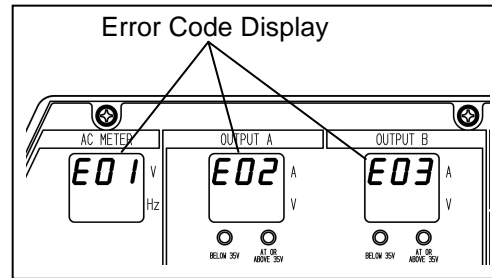

Error Code	Symptom	Remedy
E01 The overheating monitor lamp ("OVERHEAT") also flash.	Overheating of alternator and/or control parts for welding	Run the engine to cool it down at idle under no-load until the display changes from "E01" to "888". Then stop and restart the engine. * The idle control switch does not operate when this failure happens.
E02	Fault/Malfunction of control parts for welding	Stop the engine and repair the location of the fault. * DO NOT restart the engine unless the fault is repaired.
E03	Short circuit of the weld output	Stop the engine. Return the short circuit of the weld output and restart the engine.
E04	Fault/Malfunction of device for switching the weld output	Stop the engine and repair the location of the fault. * DO NOT restart the engine unless the fault is repaired.

<Note>

- Maintenance of this equipment must be performed by specialized technicians.
- When performing maintenance with doors or covers open, be sure that no other persons can accidentally come close to the equipment. Close all doors and covers if momentarily leaving the equipment unattended.
- A simple inspection cannot always resolve some problems. If you cannot resolve a problem after inspecting the equipment, request repair at the retail outlet where the equipment was purchased.

14. Engine Wiring Diagram

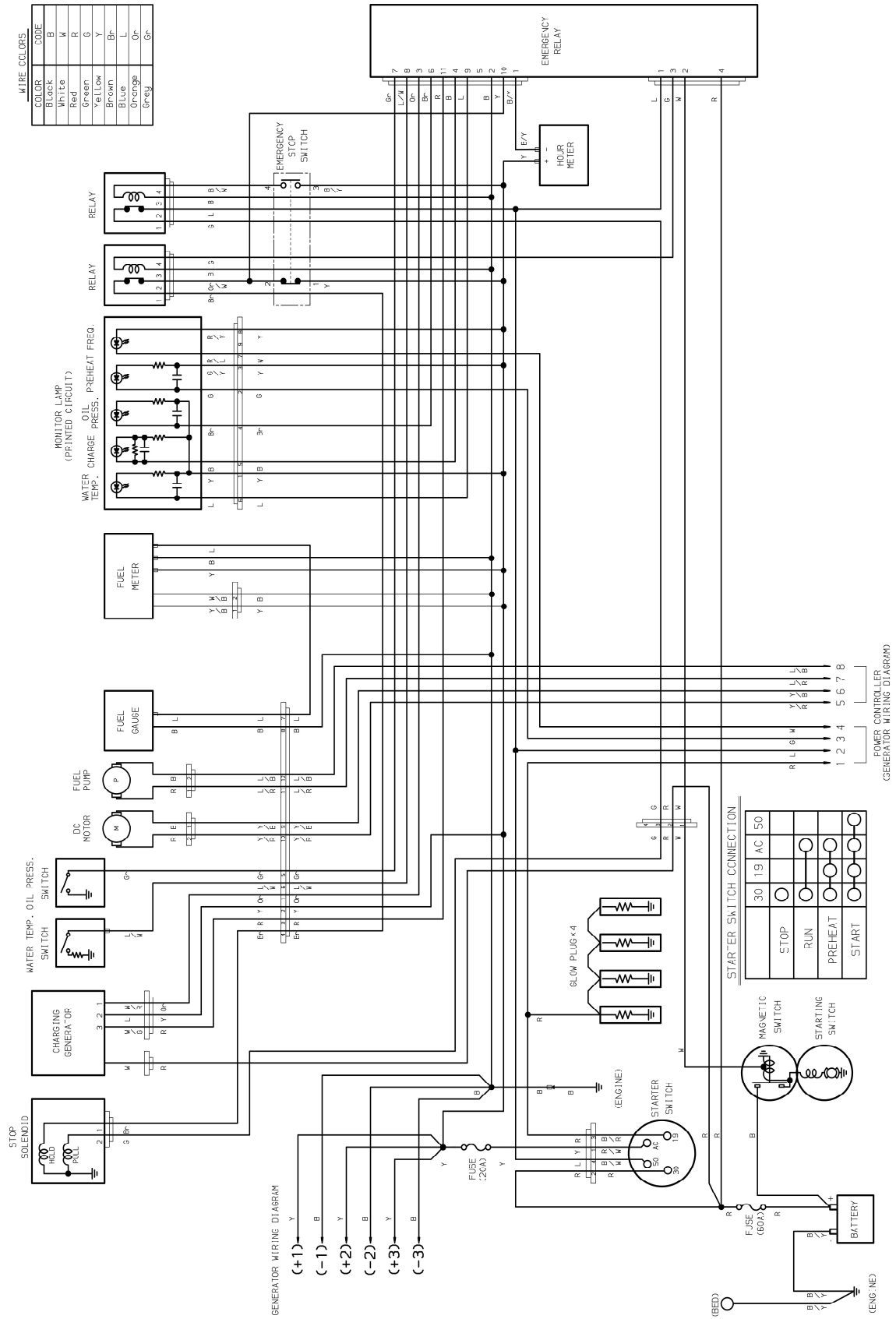

15. Generator Wiring Diagram

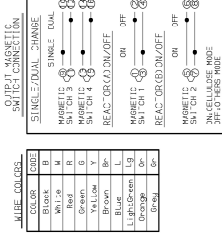
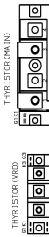
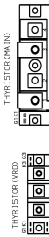
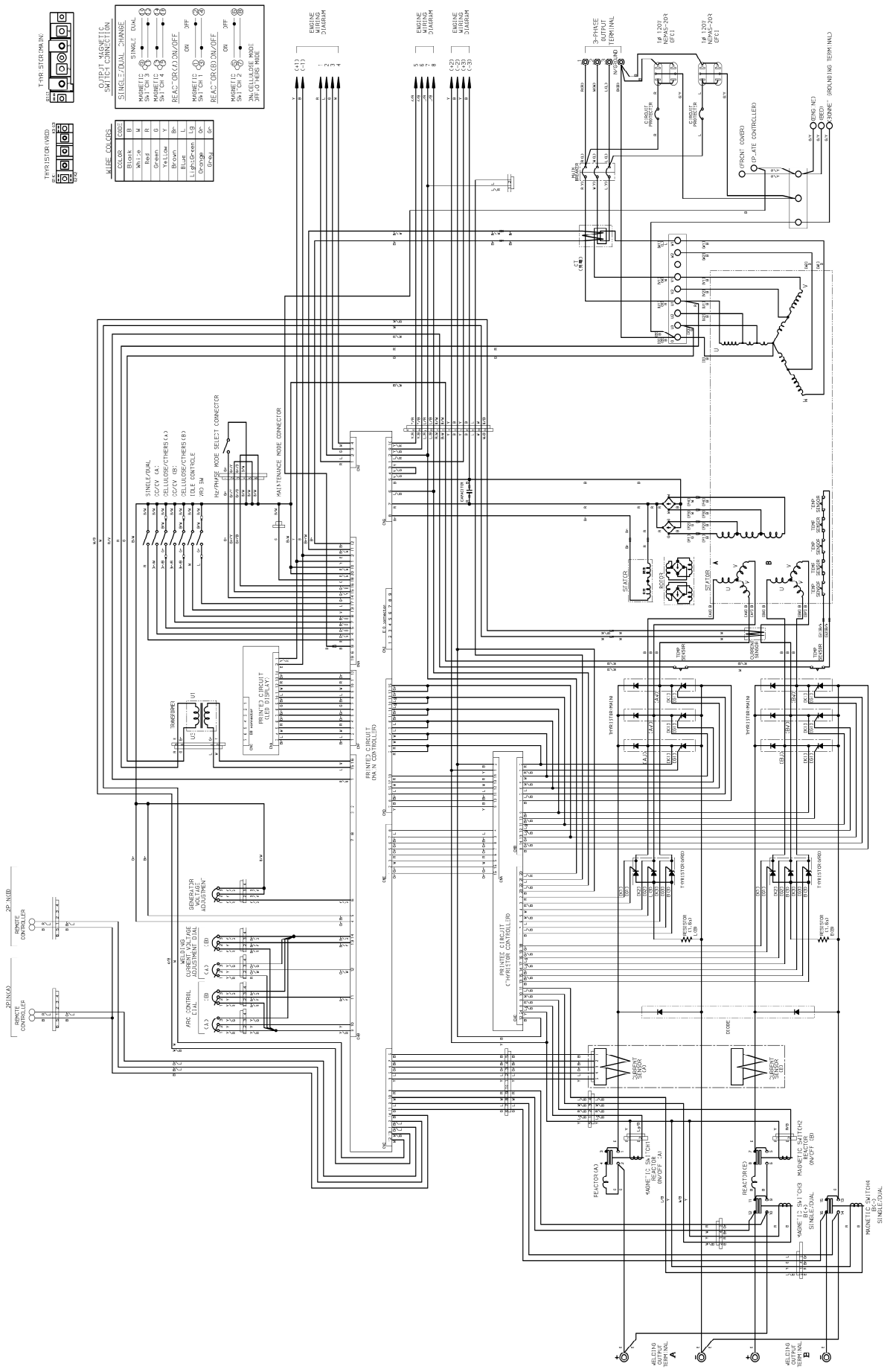

WIRE COLOR	CODE
Black	B
White	W
Orange	O
Yellow	Y
Green	G
Blue	L
Brown	BR
Grey	GR

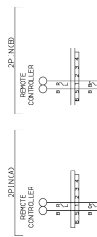
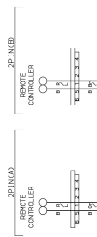
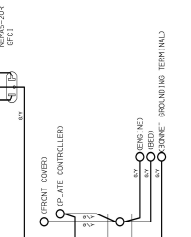
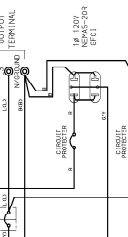
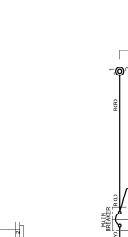
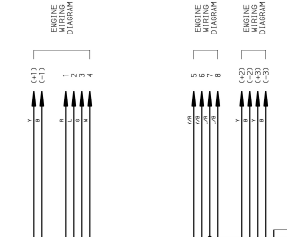

YAMABIKO CORPORATION

**7-2 SUEHIROCHO 1-CHOME, OHME, TOKYO 198-8760, JAPAN
PHONE: 81-428-32-6118. FAX: 81-428-32-6145.**

shindaiwa[®]