

## Specifications

### GENERATOR

Generator Type	Rotating Field, Brushless 3-Phase Synchronous Alternator		Winding	3-Phase, 4-Wire
Rated Output	kVA	50	Power Factor	% 80
	kW	40	Insulation Class	F
Rated Voltage	V	415	Excitation	Self-Excitation (Brushless)
Rated Current	A	69.6	Number of Poles	4
Rated Frequency	Hz	50		

### UNIT

Length	mm	1970	Dry Weight	kg	1315
Width	mm	880	Installed Weight	kg	1705
Height	mm	1665			

### ENGINE

Types	Vertical Water-Cooled 4-Cycle Diesel Engine		Fuel	Diesel Fuel (ASTM No. 2-D)
Model	V3800DI-T1 (Kubota)		Lubricant Oil	CD Class
Number of Cylinders	mm	4, 100 (bore) x 120 (stroke)	Fuel Tank Capacity	420
Continuous Rated Output	kW	49.2	Lubricant Volume	L 13.2
	PS	66.9	Cooling Water Volume	L 12.5
Rated Speed	min <sup>-1</sup>	1500	Starting Motor Capacity	V-kW 12-3.0
Displacement	L	3.769	Charging Dynamo Capacity	V-W 12-80
Combustion System	Direct Fuel Injection with Turbo Charger		Battery	130E41R
Cooling Method	Radiator			
Lubricating Method	Forced Lubrication			
Starting Method	Electric Start			

Powered by Kubota

DG50MK-P/ANZ

Control Panel

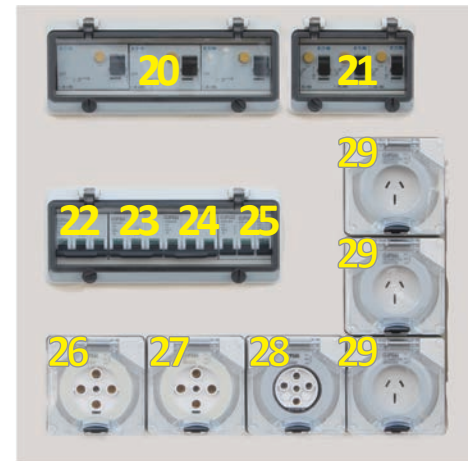
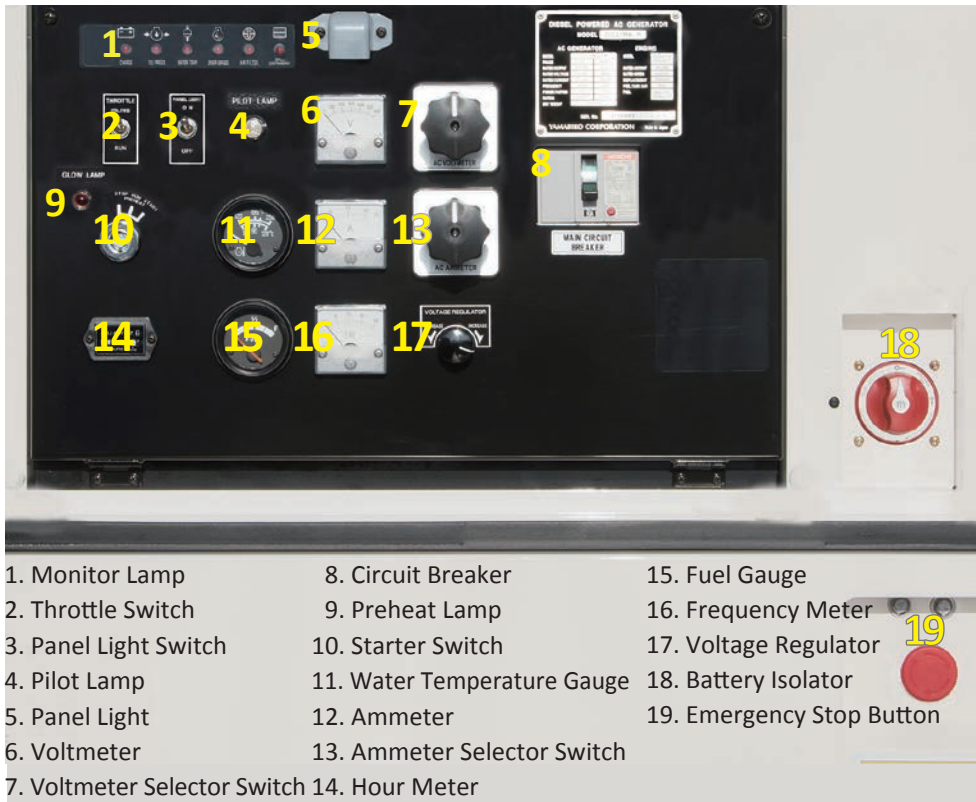

AC Output Panel

- |                           |                              |
|---------------------------|------------------------------|
| 20. 3-Phase ELCB          | 25. 1-Phase Receptacle (15A) |
| 21. 1-Phase ELCB          | 26. 3-Phase Receptacle (50A) |
| 22. 3-Phase Breaker (50A) | 27. 3-Phase Receptacle (32A) |
| 23. 3-Phase Breaker (32A) | 28. 3-Phase Receptacle (20A) |
| 24. 3-Phase Breaker (20A) | 29. 1-Phase Receptacle (15A) |

Features

Large Fuel Tank

The larger capacity fuel tank enables longer periods operation on a single tank of fuel: the unit runs for 70 hours under 50 % of load.

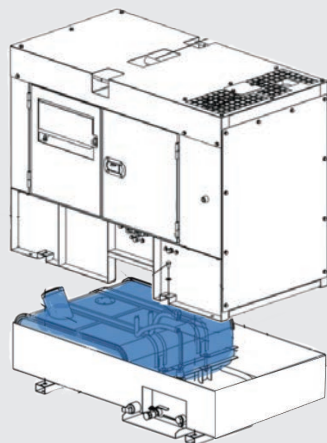

Emergency Stop Button

You can stop the engine immediately in emergency conditions to avert hazardous situations.



Spill Containment

The unit is more responsive to the nature. A spill containment captures any engine fluids to protect the surrounding environment.



Reliable KUBOTA Engine

DG50MK-P/ANZ is equipped with KUBOTA V3800D1-T. KUBOTA world-wide service network offers extensive services which includes parts replacement and repair.

