

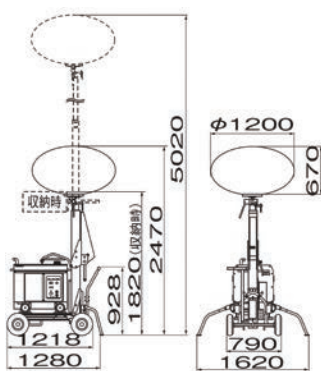

Specifications

Balloon Light Tower			Unit		
Frequency	(Hz)	50	Maximum height	(mm)	5020~2470
Lamp	Type x number of light	1000W Metal halide x 1	Minimum dimensions	(mm)	1280(L) x 790(W) x 1820(H)
	Total luminous flux	110000	Total weight	(kg)	303

Balloon stabilizer	Phase advancing	
Mast	Number of row	3
	Material	Hard aluminum
	Elevator	Hand winch
	Fall preventive device	Stopper pin
Wagon	Wheel	φ 300mm Pneumatic tire
	Break	Foot break
	Outrigger	Lift type x 2
Dry weight	(kg)	135



Shindaiwa brand light tower is dedicated for construction site with stable bright lighting, low noise and low fuel consumption.

Equipped Generator

Model	IDG3100M
Output	(kVA) 3.1
Starting method	Electric start
Fuel (Tank capacity)	Diesel(15.5L)
Continuous operation	(H) 21
Noise level	(dB(A)) 59
Oil caution device	Equipped
Dry weight	(kg) 168

Small and compact design enables operator to transport the unit by forklift easily.

